

Miniature circuit breakers **A**

Residual current circuit breakers **B**

- A.2 Five good reasons to appreciate the AEG MCBs
- A.3 Benefits of the MCBs - Series E90
- A.5 Selection table

Busbar systems **C**

- A.6 **Series E90N** - Miniature circuit breakers 3kA
- A.8 **Series E90E** - Miniature circuit breakers 4.5kA
- A.10 **Series E90** - Miniature circuit breakers 6kA
- A.12 **Series E90S** - Miniature circuit breakers 10kA
- A.14 **Series E90X** - Miniature circuit breakers 25kA
- A.16 **Series E90S UC** - Miniature circuit breakers 10kA
- A.18 **Series E880** - Miniature circuit breakers 6kA
- A.20 **Series E880S** - Miniature circuit breakers 10kA
- A.22 **Series S90** - Miniature circuit breakers 25kA
- A.24 Add-on devices
- A.25 Accessories

Comfort functions/Energy control **D**

Residential enclosures **E**

- A.26 Technical data
- A.28 Short-circuit capacity
- A.30 IEC 60898-1 versus IEC 60947-2 standard
- A.31 Influence of ambient temperature

Contactors/Soft starters/Speed drives **F**

Overload relays **G**

Control and signalling units **H**

- A.33 **Unibis™** - Compact miniature circuit breakers
- A.51 **Fixwell™** - Screwless miniature circuit breakers

Manual motor starters **I**

Moulded case circuit breakers **J**

Air circuit breakers **K**

Fuse systems/Loadbreak disconnectors **L**

General purpose enclosures **M**

System enclosures **N**

Numerical index **X**

Five good reasons to appreciate the AEG miniature circuit breakers: Line protection



1. Total protection

AEG Low Voltage MCBs provide the best answer to the obligation of circuit protection. They give comprehensive protection to circuits against:

- Overload currents (0.5A to 125A)
- Short-circuit currents (3000 up to 50000 A)
- Earth fault currents (30mA up to 1000mA) - combined with RCDs
- The handle being sealable or equipped with padlock bracket avoids dangerous operation changes (ON / OFF)
- The handle provides a clear indication of the contact position
- Top and bottom protection caps give safe installation facilities
- Sealing accessories for top and bottom connections allow protection of original wiring
- Adequate printing of all data on the front provides long-term identification



2. Total quality

- The MCBs are able to accomplish the line protection for more than 10.000 times, by a simple manual, or motor operated reset
- The quality of the shells can cope with the hardest ambient circumstances (-25°C to +55°C)
- All MCBs are current limiting MCBs, the let-through energy being reduced far below the standard limits. Energy limiting class: 3
- The low let-through peak-currents ensure the long life-time of the contacts of isolators or loadbreak switches upstream
- The emission of ionised gases are limited to the severest restrictions (35 mm grid distance)



3. A wide range

AEG Low Voltage offers:

- MCBs for household in accordance with: IEC 60898-1 - B, C and D tripping characteristics
- MCBs for industry in accordance with: IEC 60947-2 - instantaneous tripping 3-5 In, 5-10 In, 10-20 In
- MCBs in accordance with: IEC 1009 - BS 4293



4. Stock reducing system

The residential and industrial markets are covered by five appropriate series of MCBs: Series E.

Their external advantages allow the consumer to extend the MCB at any time with:

- A wide range of RCDs / people protection
- Five types of display contacts
- Shunt trip releases
- Accessories



5. Time saving connections

Insulated or non insulated busbar systems with maximum connection possibilities, can be very fast put on the top or bottom terminals of the MCBs.

Benefits of the MCBs Series E90



Safety terminal:
 - easy wiring
 - no wrong fixing
 - protection degree IP20

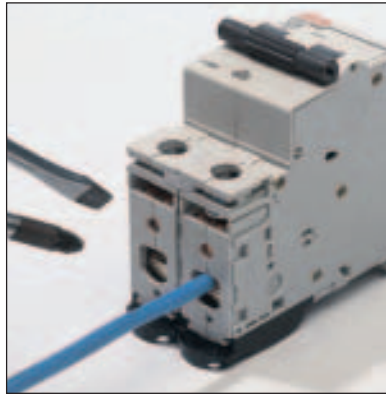

Pozidriv and slot screw head.
 Torque up to 4.5 Nm.



Incoming/outgoing terminal capacity
 up to 35 mm² or 2 x 16 mm².



Terminal side for fork busbar is
 isolated between the poles.



Two positions of the DIN-rail clip.
 Easy installation.

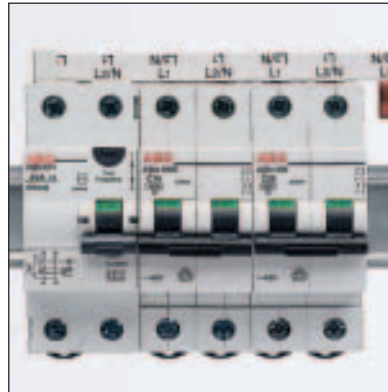

MCBs and RCCBs can be connected
 with PIN type busbar at the top
 terminals.

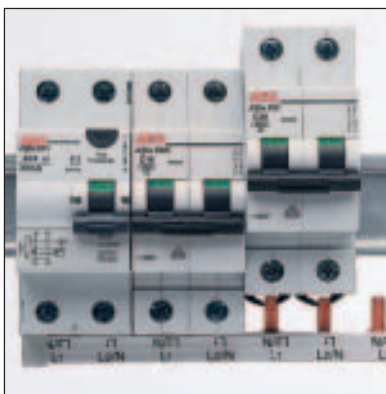

MCBs and RCCBs can be connected
 with PIN type busbar at the bottom
 terminals, with easy DIN-rail
 extraction.

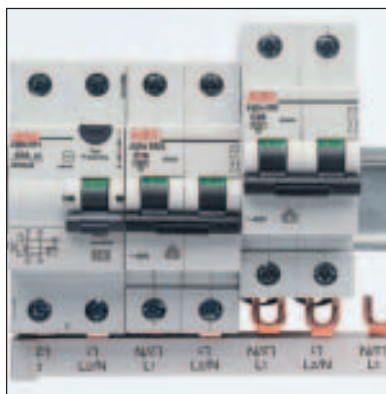

MCBs and RCCBs can be connected
 with FORK type busbar at the bottom
 terminals, with easy DIN-rail
 extraction.



Auxiliary contacts can be added on
 the left hand side of the MCB.

Notes

A large grid of graph paper for taking notes, consisting of 20 columns and 30 rows of small squares.

Selection table of MCBs

Page no.	Series	Applications	Poles	Add-on devices	Tripping characteristic	Rating current (A)	Short-circuit capacity (kA)
A.6	E90N		1, 2, 3, 4	yes	B	6-40	3, 5, 10
				yes	C	2-40	3, 5, 10
A.8	E90E		1, 1+N, 2, 3, 3+N, 4	yes	B	6-40	4.5, 6, 14
				yes	C	2-40	4.5, 6, 14
A.10	E90	 	1, 1+N, 2, 3, 3+N, 4	yes	B	6-63	6, 10, 20
				yes	C	0.5-63	6, 10, 20
				yes	D	0.5-63	6, 10, 20
				yes	K	0.5-63	6, 10, 20
A.12	E90S	 	1, 1+N, 2, 3, 3+N, 4	yes	B	6-63	10, 15, 30
				yes	C	0.5-63	10, 15, 30
				yes	D	0.5-63	10, 15, 30
A.14	E90X		1, 2, 3, 4	yes	B	6-63	15, 20, 25
				yes	C	0.5-63	15, 20, 25
				yes	D	0.5-63	15, 20, 25
A.16	E90S UC		1, 2	yes	B	6-63	6, 10
				yes	C	0.5-63	6, 10
A.18	E880	 	1, 2, 3, 4	yes	B	80-125	6, 10
				yes	C	80-125	6, 10
				yes	D	80-125	6, 10
A.20	E880S	 	1, 2, 3, 4	yes	B	80-125	10, 15
				yes	C	80-125	10, 15
				yes	D	80-125	10, 15
A.22	S90	 	1, 3x1, 3, 1+N, 3+N	(1)	Cs	10-100	25
			1, 3x1	(1)	E	10-100	25
			1, 3x1	(1)	F	10-100	25

(1) on request



B : 3-5 In
C : 5-10 In
D : 10-20 In

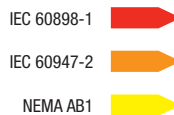

Compact MCBs
1P+N in 1 module
2P in 1 module
3P in 2 modules
4P in 2 modules
Series EC, page A.33-A.49

Screwless MCBs
6 kA
10 kA
Series E...P, page A.51-A.63

Miniature circuit breakers

Series E90N



DIN VDE 0641 **3kA**
EN/IEC 60898-1 3000
3
EN/IEC 60947-2 **5kA**

Applications



Approval/Marking



Add-on devices

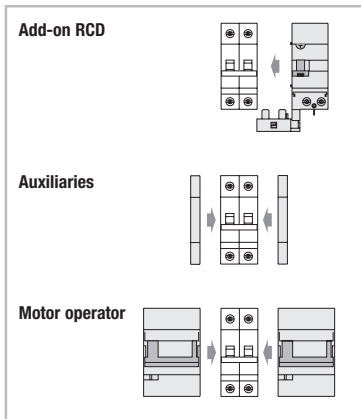

- Add-on RCD ● pg B.15
- Auxiliary contacts ● pg A.24
- Shunt trip ● pg A.24
- Undervoltage release ● pg A.24
- Motor operator ● pg A.24

- Accessories ● pg A.25
- Busbars ● chapter C
- Dimensions ● pg A.7

Performance

Thermal setting (In)	(A)	2-40
Rated voltage AC (Un)	(V)	240/415
Minimum operating voltage $U_{B \min}$	(V)	12
Tripping characteristics		B-C
Selectivity class		3
Mechanical/electrical endurance		20000/10000
Tropicalisation acc.to IEC 60068-2		95%RH at 55°C
Terminal capacity flexible/rigid cable	(mm ²)	25-35
Poles		1, 2, 3, 4
Weight	(g/pole)	120
Thermal operating limit		(1.13 - 1.45) x In
Magnetic operating		B: (3 - 5) x In C: (5 - 10) x In

Short-circuit capacity

Acc. to EN/IEC 60898-1

Poles	V	Icn/Ics (kA)
1-4	230/400	3

AC acc. to EN/IEC 60947-2

Poles	V	Icu (kA)
1	240	5
2	127	-
	240	10
	415	5
3, 4	240	10
	415	5

Series E90N - 3kA - AC MCBs



1P
1 mod.



Pole width	Rated current [A]	B		C		Pack.
		Cat. No.	Ref. No.	Cat. No.	Ref. No.	
18mm	2	-	-	E91N C02	552466	12
	4	-	-	E91N C04	552468	12
	6	E91N B06	552405	E91N C06	552469	12
	10	E91N B10	552407	E91N C10	552471	12
	16	E91N B16	552409	E91N C16	552473	12
	20	E91N B20	552410	E91N C20	552474	12
	25	E91N B25	552411	E91N C25	552475	12
	32	E91N B32	552412	E91N C32	552476	12
	40	E91N B40	552413	E91N C40	552477	12



2P
2 mod.

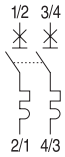

18mm	2	-	-	E92N C02	552482	6
	4	-	-	E92N C04	552484	6
	6	E92N B06	552421	E92N C06	552485	6
	10	E92N B10	552423	E92N C10	552487	6
	16	E92N B16	552425	E92N C16	552489	6
	20	E92N B20	552426	E92N C20	552490	6
	25	E92N B25	552427	E92N C25	552491	6
	32	E92N B32	552428	E92N C32	552492	6
	40	E92N B40	552429	E92N C40	552493	6

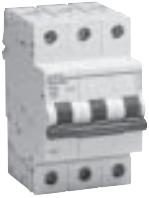

3P
3 mod.

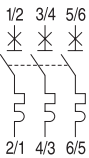

18mm	2	-	-	E93N C02	552498	4
	4	-	-	E93N C04	552500	4
	6	E93N B06	552437	E93N C06	552501	4
	10	E93N B10	552439	E93N C10	552503	4
	16	E93N B16	552441	E93N C16	552505	4
	20	E93N B20	552442	E93N C20	552506	4
	25	E93N B25	552443	E93N C25	552507	4
	32	E93N B32	552444	E93N C32	552508	4
	40	E93N B40	552445	E93N C40	552509	4

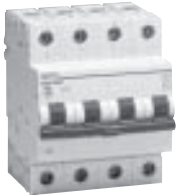

4P
4 mod.

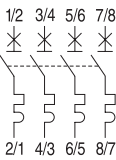

18mm	2	-	-	E94N C02	552514	3
	4	-	-	E94N C04	552516	3
	6	E94N B06	552453	E94N C06	552517	3
	10	E94N B10	552455	E94N C10	552519	3
	16	E94N B16	552457	E94N C16	552521	3
	20	E94N B20	552458	E94N C20	552522	3
	25	E94N B25	552459	E94N C25	552523	3
	32	E94N B32	552460	E94N C32	552524	3
	40	E94N B40	552461	E94N C40	552525	3

Dimensions - Series E90N, E90E, E90, E90S, E90S UC, E90X

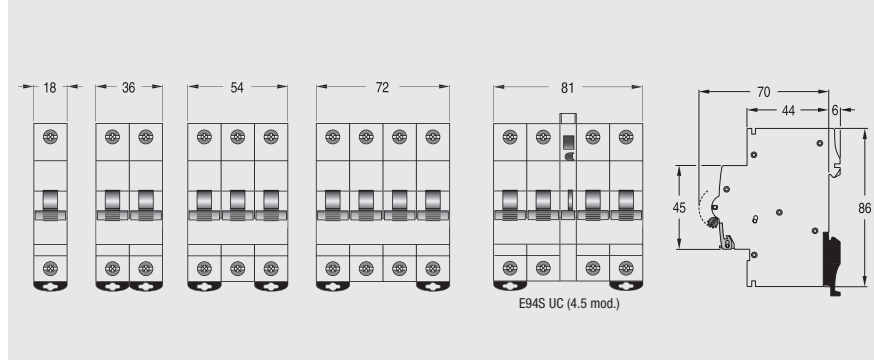

Miniature circuit breakers

Series E90E



DIN VDE 0641	4.5kA
EN/IEC 60898-1	4500
	3
EN/IEC 60947-2	6kA

Applications



Approval/Marking



Add-on devices

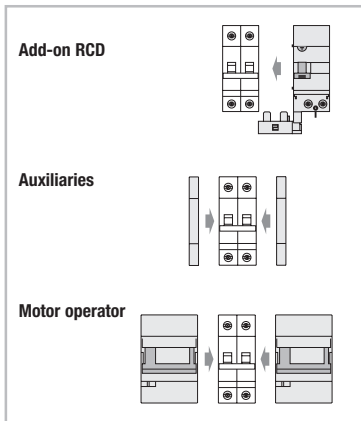

- Add-on RCD ● pg B.15
- Auxiliary contacts ● pg A.24
- Shunt trip ● pg A.24
- Undervoltage release ● pg A.24
- Motor operator ● pg A.24

- Accessories ● pg A.25
- Busbars ● chapter C
- Dimensions ● pg A.7

Performance

Thermal setting (I_n)	(A)	2-40
Rated voltage AC (U_n)	(V)	240/415
Minimum operating voltage U_{B min}	(V)	12
Tripping characteristics		B-C
Selectivity class		3
Mechanical/electrical endurance		20000/10000
Tropicalisation acc.to IEC 60068-2		95%RH at 55°C
Terminal capacity flexible/rigid cable	(mm ²)	25-35
Poles		1, 1+N, 2, 3, 3+N, 4
Weight	(g/pole)	120
Thermal operating limit		(1.13 - 1.45) x I _n
Magnetic operating		B: (3 - 5) x I _n C: (5 - 10) x I _n

Short-circuit capacity

AC acc. to EN/IEC 60898-1

Poles	V	I _{cn} /I _{cs} (kA)
1-4	230/400	4.5

AC acc. to EN/IEC 60947-2

Poles	V	I _{cu} (kA)
1	240	6
2	127	15
	240	10
	415	6
3, 4	240	10
	415	6

Series E90E - 4.5kA - AC MCBs



**1P
1 mod.**



Pole width	Rated current [A]	B		C		Pack.
		Cat. No.	Ref. No.	Cat. No.	Ref. No.	
18mm	2	E91 B02	688494	E91E C02	552610	12
	4	E91 B04	688495	E91E C04	552612	12
	6	E91E B06	552533	E91E C06	552613	12
	10	E91E B10	552535	E91E C10	552615	12
	16	E91E B16	552537	E91E C16	552617	12
	20	E91E B20	552538	E91E C20	552618	12
	25	E91E B25	552539	E91E C25	552619	12
	32	E91E B32	552540	E91E C32	552620	12
40	E91E B40	552541	E91E C40	552621	12	



**2P
2 mod.**

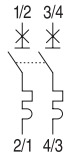

18mm	2	-	-	E92E C02	552626	6
	4	-	-	E92E C04	552628	6
	6	E92E B06	552549	E92E C06	552629	6
	10	E92E B10	552551	E92E C10	552631	6
	16	E92E B16	552553	E92E C16	552633	6
	20	E92E B20	552554	E92E C20	552634	6
	25	E92E B25	552555	E92E C25	552635	6
	32	E92E B32	552556	E92E C32	552636	6
40	E92E B40	552557	E92E C40	552637	6	

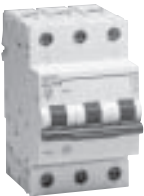

**3P
3 mod.**

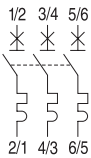

18mm	2	-	-	E93E C02	552642	4
	4	-	-	E93E C04	552644	4
	6	E93E B06	552565	E93E C06	552645	4
	10	E93E B10	552567	E93E C10	552647	4
	16	E93E B16	552569	E93E C16	552649	4
	20	E93E B20	552570	E93E C20	552650	4
	25	E93E B25	552571	E93E C25	552651	4
	32	E93E B32	552572	E93E C32	552652	4
40	E93E B40	552573	E93E C40	552653	4	



**4P
4 mod.**

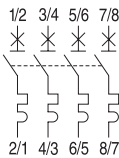

18mm	2	-	-	E94E C02	552658	3
	4	-	-	E94E C04	552660	3
	6	E94E B06	552581	E94E C06	552661	3
	10	E94E B10	552583	E94E C10	552663	3
	16	E94E B16	552585	E94E C16	552665	3
	20	E94E B20	552586	E94E C20	552666	3
	25	E94E B25	552587	E94E C25	552667	3
	32	E94E B32	552588	E94E C32	552668	3
40	E94E B40	552589	E94E C40	552669	3	



**1P+N
2 mod.**



18mm	2	-	-	E91E C02 N	552672	6
	4	-	-	E91E C04 N	552673	6
	6	E91E B06 N	552592	E91E C06 N	552674	6
	10	E91E B10 N	552593	E91E C10 N	552675	6
	13	E91E B13 N	552594	E91E C13 N	552676	6
	16	E91E B16 N	552595	E91E C16 N	552677	6
	20	E91E B20 N	552596	E91E C20 N	552678	6
	25	E91E B25 N	552597	E91E C25 N	552679	6
32	E91E B32 N	552598	E91E C32 N	552680	6	
40	E91E B40 N	552599	E91E C40 N	552681	6	



**3P+N
4 mod.**

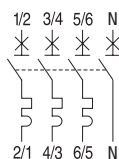

18mm	2	-	-	E93E C02 N	552682	3
	4	-	-	E93E C04 N	552683	3
	6	E93E B06 N	552600	E93E C06 N	552684	3
	10	E93E B10 N	552601	E93E C10 N	552685	3
	13	E93E B13 N	552602	E93E C13 N	552686	3
	16	E93E B16 N	552603	E93E C16 N	552687	3
	20	E93E B20 N	552604	E93E C20 N	552688	3
	25	E93E B25 N	552605	E93E C25 N	552689	3
	32	E93E B32 N	552606	E93E C32 N	552690	3
	40	E93E B40 N	552607	E93E C40 N	552691	3

Miniature circuit breakers

Series E90



DIN VDE 0641 **6kA**
EN/IEC 60898-1 **6000**
3
EN/IEC 60947-2 **10kA**

Applications



Approval/Marking



Add-on devices

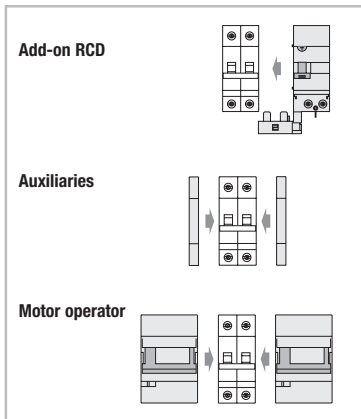

- Add-on RCD ● pg B.15
- Auxiliary contacts ● pg A.24
- Shunt trip ● pg A.24
- Undervoltage release ● pg A.24
- Motor operator ● pg A.24

- Accessories ● pg A.25
- Busbars ● chapter C
- Dimensions ● pg A.7

Performance

Thermal setting (I_n)	(A)	0.5-63
Rated voltage AC (U_n)	(V)	240/415
Minimum operating voltage U_{B min}	(V)	12
Tripping characteristics		B-C-D-K
Selectivity class		3
Mechanical/electrical endurance		20000/10000
Tropicalisation acc.to IEC 60068-2		95%RH at 55°C
Terminal capacity flexible/rigid cable	(mm ²)	25-35
Poles		1, 1+N, 2, 3, 3+N, 4
Weight	(g/pole)	120
Thermal operating limit		(1.13 - 1.45) x I _n
Magnetic operating		B: (3 - 5) x I _n C: (5 - 10) x I _n D: (10 - 20) x I _n K: (8 - 12) x I _n

Short-circuit capacity

AC acc. to EN/IEC 60898-1

Poles	V	I _{cn} /I _{cs} (kA)
1-4	230/400	6

AC acc. to EN/IEC 60947-2

Poles	V	I _{cu} (kA) ⁽¹⁾
1	240	10
1+N.2	127	30
	240	20
2	415	10
3, 4	240	20
	415	10









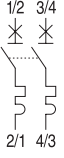

DC acc. to EN/IEC 60947-2⁽²⁾

Poles	V	I _{cu} /I _{cs} (kA)
1	60	20
2	125	25

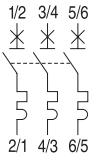
(1) I_{cs} = 75% I_{cu}

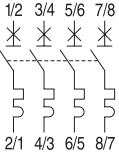
(2) Nominal and maximum VDC in page A.26-A.29

Series E90 - 6kA - AC MCBs

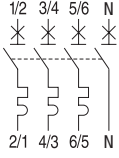
	Pole width	Rated current [A]	B		C		D		K		Pack.	
			Cat. No.	Ref. No.	Cat. No.	Ref. No.	Cat. No.	Ref. No.	Cat. No.	Ref. No.		
 <p>1P 1 mod.</p> 	18mm	0.5	-	-	E91 C0.5	552784	E91 D0.5	552876	E91K0.5	691174	12	
		1	-	-	E91 C01	552785	E91 D01	552877	E91K01	691175	12	
		1.6	-	-	-	-	-	-	E91K1.6	691181	12	
		2	E91 B02	688494	E91 C02	552786	E91 D02	552878	E91K02	691176	12	
		3	-	-	E91 C03	552787	E91 D03	552879	E91K03	691177	12	
		4	E91 B04	688495	E91 C04	552788	E91 D04	552880	E91K04	691178	12	
		6	E91 B06	552697	E91 C06	552789	E91 D06	552881	E91K06	691179	12	
		10	E91 B10	552699	E91 C10	552791	E91 D10	552883	E91K08	691180	12	
		13	E91 B13	552700	E91 C13	552792	E91 D13	552884	E91K10	691182	12	
		16	E91 B16	552701	E91 C16	552793	E91 D16	552885	E91K16	691183	12	
		20	E91 B20	552702	E91 C20	552794	E91 D20	552886	E91K20	691184	12	
		25	E91 B25	552703	E91 C25	552795	E91 D25	552887	E91K25	691185	12	
		32	E91 B32	552704	E91 C32	552796	E91 D32	552888	E91K32	691186	12	
		40	E91 B40	552705	E91 C40	552797	E91 D40	552889	E91K40	691187	12	
		50	E91 B50	552706	E91 C50	552798	E91 D50	552890	E91K50	691188	12	
		63	E91 B63	552707	E91 C63	552799	E91 D63	552891	E91K63	691189	12	
 <p>2P 2 mod.</p> 	18mm	0.5	-	-	E92 C0.5	552819	E92 D0.5	552911	E92K0.5	691610	6	
		1	-	-	E92 C01	552820	E92 D01	552912	E92K01	691611	6	
		1.6	-	-	-	-	-	-	E92K1.6	691612	6	
		2	-	-	E92 C02	552821	E92 D02	552913	E92K02	691613	6	
		3	-	-	E92 C03	552822	E92 D03	552914	E92K03	691614	6	
		4	-	-	E92 C04	552823	E92 D04	552915	E92K04	691615	6	
		6	E92 B06	552732	E92 C06	552824	E92 D06	552916	E92K06	691616	6	
		10	E92 B10	552734	E92 C10	552826	E92 D10	552918	E92K08	691617	6	
		13	E92 B13	552735	E92 C13	552827	E92 D13	552919	E92K10	691618	6	
		16	E92 B16	552736	E92 C16	552828	E92 D16	552920	E92K16	691619	6	
		20	E92 B20	552737	E92 C20	552829	E92 D20	552921	E92K20	691620	6	
		25	E92 B25	552738	E92 C25	552830	E92 D25	552922	E92K25	691621	6	
		32	E92 B32	552739	E92 C32	552831	E92 D32	552923	E92K32	691622	6	
		40	E92 B40	552740	E92 C40	552832	E92 D40	552924	E92K40	691623	6	
		50	E92 B50	552741	E92 C50	552833	E92 D50	552925	E92K50	691624	6	
		63	E92 B63	552742	E92 C63	552834	E92 D63	552926	E92K63	691625	6	
 <p>3P 3 mod.</p> 	18mm	0.5	-	-	E93 C0.5	552838	E93 D0.5	552930	E93K0.5	691190	4	
		1	-	-	E93 C01	552839	E93 D01	552931	E93K01	691191	4	
		1.6	-	-	-	-	-	-	E93K1.6	691197	4	
		2	-	-	E93 C02	552840	E93 D02	552932	E93K02	691192	4	
		3	-	-	E93 C03	552841	E93 D03	552933	E93K03	691193	4	
		4	-	-	E93 C04	552842	E93 D04	552934	E93K04	691194	4	
		6	E93 B06	552751	E93 C06	552843	E93 D06	552935	E93K06	691195	4	
		10	E93 B10	552753	E93 C10	552845	E93 D10	552937	E93K08	691196	4	
		13	E93 B13	552754	E93 C13	552846	E93 D13	552938	E93K10	691198	4	
		16	E93 B16	552755	E93 C16	552847	E93 D16	552939	E93K16	691199	4	
		20	E93 B20	552756	E93 C20	552848	E93 D20	552940	E93K20	691200	4	
		25	E93 B25	552757	E93 C25	552849	E93 D25	552941	E93K25	691201	4	
		32	E93 B32	552758	E93 C32	552850	E93 D32	552942	E93K32	691202	4	
		40	E93 B40	552759	E93 C40	552851	E93 D40	552943	E93K40	691203	4	
		50	E93 B50	552760	E93 C50	552852	E93 D50	552944	E93K50	691204	4	
		63	E93 B63	552761	E93 C63	552853	E93 D63	552945	E93K63	691205	4	
 <p>4P 4 mod.</p> 	18mm	0.5	-	-	E94 C0.5	552857	E94 D0.5	552949	-	-	3	
		1	-	-	E94 C01	552858	E94 D01	552950	-	-	-	3
		2	-	-	E94 C02	552859	E94 D02	552951	-	-	-	3
		3	-	-	E94 C03	552860	E94 D03	552952	-	-	-	3
		4	-	-	E94 C04	552861	E94 D04	552953	-	-	-	3
		6	E94 B06	552770	E94 C06	552862	E94 D06	552954	-	-	-	3
		10	E94 B10	552772	E94 C10	552864	E94 D10	552956	-	-	-	3
		13	E94 B13	552773	E94 C13	552865	E94 D13	552957	-	-	-	3
		16	E94 B16	552774	E94 C16	552866	E94 D16	552958	-	-	-	3
		20	E94 B20	552775	E94 C20	552867	E94 D20	552959	-	-	-	3
		25	E94 B25	552776	E94 C25	552868	E94 D25	552960	-	-	-	3
		32	E94 B32	552777	E94 C32	552869	E94 D32	552961	-	-	-	3
		40	E94 B40	552778	E94 C40	552870	E94 D40	552962	-	-	-	3
		50	E94 B50	552779	E94 C50	552871	E94 D50	552963	-	-	-	3
		63	E94 B63	552780	E94 C63	552872	E94 D63	552964	-	-	-	3
		 <p>1P+N 2 mod.</p> 	18mm	0.5	-	-	E91 C0.5 N	552803	E91 D0.5 N	552895	-	-
1	-			-	E91 C01 N	552804	E91 D01 N	552896	-	-	-	6
2	-			-	E91 C02 N	552805	E91 D02 N	552897	-	-	-	6
3	-			-	E91 C03 N	552806	E91 D03 N	552898	-	-	-	6
4	-			-	E91 C04 N	552807	E91 D04 N	552899	-	-	-	6
6	E91 B06 N			552716	E91 C06 N	552808	E91 D06 N	552900	-	-	-	6
10	E91 B10 N			552718	E91 C10 N	552810	E91 D10 N	552902	-	-	-	6
13	E91 B13 N			552719	E91 C13 N	552811	E91 D13 N	552903	-	-	-	6
16	E91 B16 N			552720	E91 C16 N	552812	E91 D16 N	552904	-	-	-	6
20	E91 B20 N			552721	E91 C20 N	552813	E91 D20 N	552905	-	-	-	6
25	E91 B25 N			552722	E91 C25 N	552814	E91 D25 N	552906	-	-	-	6
32	E91 B32 N			552723	E91 C32 N	552815	E91 D32 N	552907	-	-	-	6
40	E91 B40 N			552724	E91 C40 N	552816	E91 D40 N	552908	-	-	-	6
50	E91 B50 N			552725	E91 C50 N	552817	E91 D50 N	552909	-	-	-	6
63	E91 B63 N			552726	E91 C63 N	552818	E91 D63 N	552910	-	-	-	6
 <p>3P+N 4 mod.</p> 	18mm			0.5	-	-	E93 C0.5 N	681192	E93 D0.5 N	681208	-	-
		1	-	-	E93 C01 N	681193	E93 D01 N	681209	-	-	-	3
		2	-	-	E93 C02 N	681194	E93 D02 N	681210	-	-	-	3
		3	-	-	E93 C03 N	681195	E93 D03 N	681211	-	-	-	3
		4	-	-	E93 C04 N	681196	E93 D04 N	681212	-	-	-	3
		6	E93 B06 N	681181	E93 C06 N	681197	E93 D06 N	681213	-	-	-	3
		10	E93 B10 N	681183	E93 C10 N	681199	E93 D10 N	681215	-	-	-	3
		13	E93 B13 N	681184	E93 C13 N	681200	E93 D13 N	681216	-	-	-	3
		16	E93 B16 N	681185	E93 C16 N	681201	E93 D16 N	681217	-	-	-	3
		20	E93 B20 N	681186	E93 C20 N	681202	E93 D20 N	681218	-	-	-	3
		25	E93 B25 N	681187	E93 C25 N	681203	E93 D25 N	681219	-	-	-	3
		32	E93 B32 N	681188	E93 C32 N	681204	E93 D32 N	681220	-	-	-	3
		40	E93 B40 N	681189	E93 C40 N	681205	E93 D40 N	681221	-	-	-	3
		50	E93 B50 N	681190	E93 C50 N	681206	E93 D50 N	681222	-	-	-	3
		63	E93 B63 N	681191	E93 C63 N	681207	E93 D63 N	681223	-	-	-	3

Miniature circuit breakers

Series E90S



DIN VDE 0641	10kA
EN/IEC 60898-1	10000
	3
EN/IEC 60947-2	15kA

Applications



Approval/Marking



Add-on devices

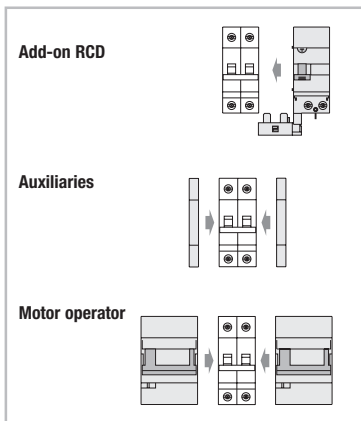

- Add-on RCD ● pg B.15
- Auxiliary contacts ● pg A.24
- Shunt trip ● pg A.24
- Undervoltage release ● pg A.24
- Motor operator ● pg A.24

- Accessories ● pg A.25
- Busbars ● chapter C
- Dimensions ● pg A.7

Performance

Thermal setting (I_n)	(A)	0.5-63
Rated voltage AC (U_n)	(V)	240/415
Minimum operating voltage U_{B min}	(V)	12
Tripping characteristics		B-C-D
Selectivity class		3
Mechanical/electrical endurance		20000/10000
Tropicalisation acc.to IEC 60068-2		95%RH at 55°C
Terminal capacity flexible/rigid cable	(mm ²)	25-35
Poles		1, 1+N, 2, 3, 3+N, 4
Weight	(g/pole)	120
Thermal operating limit		(1.13 - 1.45) x I _n
Magnetic operating		B: (3 - 5) x I _n C: (5 - 10) x I _n D: (10 - 20) x I _n

Short-circuit capacity

AC acc. to EN/IEC 60898-1

Poles	V	I _{cn} (kA) ⁽¹⁾
1-4	230/400	10

AC acc. to EN/IEC 60947-2

Poles	V	I _{cu} (kA) ⁽²⁾
1	240	15
1+N.2	127	40
	240	30
2	415	15
3, 4	240	30
	415	15

DC acc. to EN/IEC 60947-2⁽³⁾







Poles	V	I _{cu} /I _{cs} (kA)
1	60	25
2	125	30

(1) I_{cs} = 75% I_{cn}

(2) I_{cs} = 50% I_{cu}

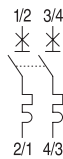
(3) Nominal and maximum VDC in page A.26-A.29

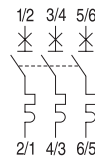
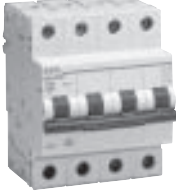
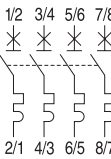
Series E90S - 10kA - AC MCBs

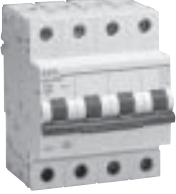
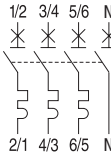
	Pole width	Rated current [A]	B		C		D		Pack.
			Cat. No.	Ref. No.	Cat. No.	Ref. No.	Cat. No.	Ref. No.	
 <p>1P 1 mod.</p> <p>1/2</p>  <p>2/1</p>	18mm	0.5	-	-	E91S C0.5	553044	E91S D0.5	553120	12
		1	-	-	E91S C01	553045	E91S D01	553121	12
		2	-	-	E91S C02	553046	E91S D02	553122	12
		3	-	-	E91S C03	553047	E91S D03	553123	12
		4	-	-	E91S C04	553048	E91S D04	553124	12
		6	E91S B06	552973	E91S C06	553049	E91S D06	553125	12
		10	E91S B10	552975	E91S C10	553051	E91S D10	553127	12
		13	E91S B13	552976	E91S C13	553052	E91S D13	553128	12
		16	E91S B16	552977	E91S C16	553053	E91S D16	553129	12
		20	E91S B20	552978	E91S C20	553054	E91S D20	553130	12
		25	E91S B25	552979	E91S C25	553055	E91S D25	553131	12
		32	E91S B32	552980	E91S C32	553056	E91S D32	553132	12
		40	E91S B40	552981	E91S C40	553057	E91S D40	553132	12
		50	E91S B50	552982	E91S C50	553058	E91S D50	553134	12
		63	E91S B63	552983	E91S C63	553059	E91S D63	553135	12
		 <p>2P 2 mod.</p> <p>1/2 3/4</p>  <p>2/1 4/3</p>	18mm	0.5	-	-	E92S C0.5	553063	E92S D0.5
1	-			-	E92S C01	553064	E92S D01	553140	6
2	-			-	E92S C02	553065	E92S D02	553141	6
3	-			-	E92S C03	553066	E92S D03	553142	6
4	-			-	E92S C04	553067	E92S D04	553143	6
6	E92S B06			552992	E92S C06	553068	E92S D06	553144	6
10	E92S B10			552994	E92S C10	553070	E92S D10	553146	6
13	E92S B13			552995	E92S C13	553071	E92S D13	553147	6
16	E92S B16			552996	E92S C16	553072	E92S D16	553148	6
20	E92S B20			552997	E92S C20	553073	E92S D20	553149	6
25	E92S B25			552998	E92S C25	553074	E92S D25	553150	6
32	E92S B32			552999	E92S C32	553075	E92S D32	553151	6
40	E92S B40			553000	E92S C40	553076	E92S D40	553152	6
50	E92S B50			553001	E92S C50	553077	E92S D50	553153	6
63	E92S B63			553002	E92S C63	553078	E92S D63	553154	6
 <p>3P 3 mod.</p> <p>1/2 3/4 5/6</p>  <p>2/1 4/3 6/5</p>	18mm			0.5	-	-	E93S C0.5	553082	E93S D0.5
		1	-	-	E93S C01	553083	E93S D01	553159	4
		2	-	-	E93S C02	553084	E93S D02	553160	4
		3	-	-	E93S C03	553085	E93S D03	553161	4
		4	-	-	E93S C04	553086	E93S D04	553162	4
		6	E93S B06	553011	E93S C06	553087	E93S D06	553163	4
		10	E93S B10	553013	E93S C10	553089	E93S D10	553165	4
		13	E93S B13	553014	E93S C13	553090	E93S D13	553166	4
		16	E93S B16	553015	E93S C16	553091	E93S D16	553167	4
		20	E93S B20	553016	E93S C20	553092	E93S D20	553168	4
		25	E93S B25	553017	E93S C25	553093	E93S D25	553169	4
		32	E93S B32	553018	E93S C32	553094	E93S D32	553170	4
		40	E93S B40	553019	E93S C40	553095	E93S D40	553171	4
		50	E93S B50	553020	E93S C50	553096	E93S D50	553172	4
		63	E93S B63	553021	E93S C63	553097	E93S D63	553173	4
		 <p>4P 4 mod.</p> <p>1/2 3/4 5/6 7/8</p>  <p>2/1 4/3 6/5 8/7</p>	18mm	0.5	-	-	E94S C0.5	553101	-
1	-			-	E94S C01	553102	E94S D01	553178	3
2	-			-	E94S C02	553103	E94S D02	553179	3
3	-			-	E94S C03	553104	E94S D03	553180	3
4	-			-	E94S C04	553105	E94S D04	553181	3
6	E94S B06			553030	E94S C06	553106	E94S D06	553182	3
10	E94S B10			553032	E94S C10	553108	E94S D10	553184	3
13	E94S B13			553033	E94S C13	553109	E94S D13	553185	3
16	E94S B16			553034	E94S C16	553110	E94S D16	553186	3
20	E94S B20			553035	E94S C20	553111	E94S D20	553187	3
25	E94S B25			553036	E94S C25	553112	E94S D25	553188	3
32	E94S B32			553037	E94S C32	553113	E94S D32	553189	3
40	E94S B40			553038	E94S C40	553114	E94S D40	553190	3
50	E94S B50			553039	E94S C50	553115	E94S D50	553191	3
63	E94S B63			553040	E94S C63	553116	E94S D63	553192	3
 <p>1P+N 2 mod.</p> <p>1/2 N</p>  <p>2/1 N</p>	18mm			0.5	-	-	E91S C0.5 N	681064	E91S D0.5 N
		1	-	-	E91S C01 N	681065	E91S D01 N	681081	6
		2	-	-	E91S C02 N	681066	E91S D02 N	681082	6
		3	-	-	E91S C03 N	681067	E91S D03 N	681083	6
		4	-	-	E91S C04 N	681068	E91S D04 N	681084	6
		6	E91S B06 N	681053	E91S C06 N	681069	E91S D06 N	681085	6
		10	E91S B10 N	681055	E91S C10 N	681071	E91S D10 N	681087	6
		13	E91S B13 N	681056	E91S C13 N	681072	E91S D13 N	681088	6
		16	E91S B16 N	681057	E91S C16 N	681073	E91S D16 N	681089	6
		20	E91S B20 N	681058	E91S C20 N	681074	E91S D20 N	681090	6
		25	E91S B25 N	681059	E91S C25 N	681075	E91S D25 N	681091	6
		32	E91S B32 N	681060	E91S C32 N	681076	E91S D32 N	681092	6
		40	E91S B40 N	681061	E91S C40 N	681077	E91S D40 N	681093	6
		50	E91S B50 N	681062	E91S C50 N	681078	E91S D50 N	681094	6
		63	E91S B63 N	681063	E91S C63 N	681079	E91S D63 N	681095	6
		 <p>3P+N 4 mod.</p> <p>1/2 3/4 5/6 N</p>  <p>2/1 4/3 6/5 N</p>	18mm	0.5	-	-	E93S C0.5 N	681144	E93S D0.5 N
1	-			-	E93S C01 N	681145	E93S D01 N	681161	3
2	-			-	E93S C02 N	681146	E93S D02 N	681162	3
3	-			-	E93S C03 N	681147	E93S D03 N	681163	3
4	-			-	E93S C04 N	681148	E93S D04 N	681164	3
6	E93S B06 N			681133	E93S C06 N	681149	E93S D06 N	681165	3
10	E93S B10 N			681135	E93S C10 N	681151	E93S D10 N	681167	3
13	E93S B13 N			681136	E93S C13 N	681152	E93S D13 N	681168	3
16	E93S B16 N			681137	E93S C16 N	681153	E93S D16 N	681169	3
20	E93S B20 N			681138	E93S C20 N	681154	E93S D20 N	681170	3
25	E93S B25 N			681139	E93S C25 N	681155	E93S D25 N	681171	3
32	E93S B32 N			681140	E93S C32 N	681156	E93S D32 N	681172	3
40	E93S B40 N			681141	E93S C40 N	681157	E93S D40 N	681173	3
50	E93S B50 N			681142	E93S C50 N	681158	E93S D50 N	681174	3
63	E93S B63 N			681143	E93S C63 N	681159	E93S D63 N	681175	3

Miniature circuit breakers

Series E90X

EN/IEC 60947-2 **100kA**
25kA
20kA
15kA



Applications



Marking



Add-on devices

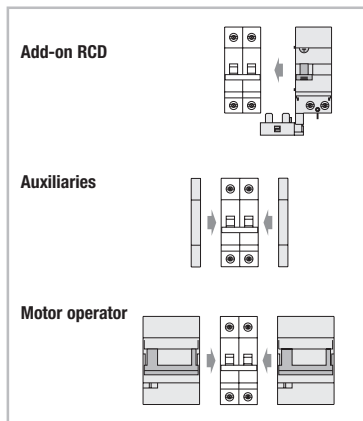

- Add-on RCD ● pg B.15
- Auxiliary contacts ● pg A.24
- Shunt trip ● pg A.24
- Undervoltage release ● pg A.24
- Motor operator ● pg A.24

- Accessories ● pg A.25
- Busbars ● chapter C
- Dimensions ● pg A.7

Performance

Thermal setting (In)	(A)	0.5-63
Rated voltage AC (Un)	(V)	240/415
Minimum operating voltage $U_{B \min}$	(V)	12
Tripping characteristics		(3 - 5) In (B) (5 - 10) In (C) (10 - 20) In (D)
Selectivity class		3
Mechanical/electrical endurance		20000/10000
Tropicalisation acc.to IEC 60068-2		95%RH at 55°C
Terminal capacity flexible/rigid cable	(mm ²)	25-35
Poles		1, 2, 3, 4
Weight	(g/pole)	120
Thermal operating limit		(1.05 - 1.30) x In
Magnetic operating		(3 - 5) In (B) (5 - 10) In (C) (10 - 20) In (D)

Short-circuit capacity

Acc. to EN/IEC 60947-2

In(A)	Poles	V	Icu (kA) ⁽¹⁾
0.5-4	1	240	100
	2-4	415	100
6-25	1	240	25
	2-4	240	50
		415	25
32-40	1	240	20
	2-4	240	40
		415	20
50-63	1	240	15
	2-4	240	30
		415	15

DC acc. to EN/IEC 60947-2⁽²⁾

Poles	V	Icu/Ics (kA)
1	60	20
2	125	25

(1) Ics = 50% Icu

(2) Nominal and maximum VDC in page A.26-A.29

Series E90X - 25kA - AC MCBs⁽¹⁾

1P
1 mod.



Pole width	Rated current [A]	B		C		D		Pack.
		Cat. No.	Ref. No.	Cat. No.	Ref. No.	Cat. No.	Ref. No.	
18mm	0.5	-	-	E91X C0.5	553400	E91X D0.5	553464	12
	1	-	-	E91X C01	553401	E91X D01	553465	12
	2	-	-	E91X C02	553402	E91X D02	553466	12
	3	-	-	E91X C03	553403	E91X D03	553467	12
	4	-	-	E91X C04	553404	E91X D04	553468	12
	6	E91X B06	553341	E91X C06	553405	E91X D06	553469	12
	10	E91X B10	553343	E91X C10	553407	E91X D10	553471	12
	13	E91X B13	553344	E91X C13	553408	E91X D13	553472	12
	16	E91X B16	553345	E91X C16	553409	E91X D16	553473	12
	20	E91X B20	553346	E91X C20	553410	E91X D20	553474	12
	25	E91X B25	553347	E91X C25	553411	E91X D25	553475	12
	32	E91X B32	553348	E91X C32	553412	E91X D32	553476	12
	40	E91X B40	553349	E91X C40	553413	E91X D40	553477	12
	50	E91X B50	553350	E91X C50	553414	E91X D50	553478	12
	63	E91X B63	553351	E91X C63	553415	E91X D63	553479	12

2P
2 mod.

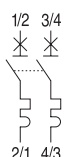

18mm	0.5	-	-	E92X C0.5	553416	E92X D0.5	553480	6
	1	-	-	E92X C01	553417	E92X D01	553481	6
	2	-	-	E92X C02	553418	E92X D02	553482	6
	3	-	-	E92X C03	553419	E92X D03	553483	6
	4	-	-	E92X C04	553420	E92X D04	553484	6
	6	E92X B06	553357	E92X C06	553421	E92X D06	553485	6
	10	E92X B10	553359	E92X C10	553423	E92X D10	553487	6
	13	E92X B13	553360	E92X C13	553424	E92X D13	553488	6
	16	E92X B16	553361	E92X C16	553425	E92X D16	553489	6
	20	E92X B20	553362	E92X C20	553426	E92X D20	553490	6
	25	E92X B25	553363	E92X C25	553427	E92X D25	553491	6
	32	E92X B32	553364	E92X C32	553428	E92X D32	553492	6
	40	E92X B40	553365	E92X C40	553429	E92X D40	553493	6
	50	E92X B50	553366	E92X C50	553430	E92X D50	553494	6
	63	E92X B63	553367	E92X C63	553431	E92X D63	553495	6

3P
3 mod.

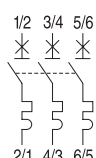

18mm	0.5	-	-	E93X C0.5	553432	E93X D0.5	553496	4
	1	-	-	E93X C01	553433	E93X D01	553497	4
	2	-	-	E93X C02	553434	E93X D02	553498	4
	3	-	-	E93X C03	553435	E93X D03	553499	4
	4	-	-	E93X C04	553436	E93X D04	553500	4
	6	E93X B06	553373	E93X C06	553437	E93X D06	553501	4
	10	E93X B10	553375	E93X C10	553439	E93X D10	553503	4
	13	E93X B13	553376	E93X C13	553440	E93X D13	553504	4
	16	E93X B16	553377	E93X C16	553441	E93X D16	553505	4
	20	E93X B20	553378	E93X C20	553442	E93X D20	553506	4
	25	E93X B25	553379	E93X C25	553443	E93X D25	553507	4
	32	E93X B32	553380	E93X C32	553444	E93X D32	553508	4
	40	E93X B40	553381	E93X C40	553445	E93X D40	553509	4
	50	E93X B50	553382	E93X C50	553446	E93X D50	553510	4
	63	E93X B63	553383	E93X C63	553447	E93X D63	553511	4

4P
4 mod.

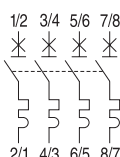
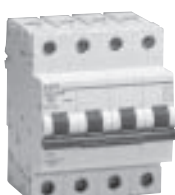

18mm	0.5	-	-	E94X C0.5	553448	E94X D0.5	553512	3
	1	-	-	E94X C01	553449	E94X D01	553513	3
	2	-	-	E94X C02	553450	E94X D02	553514	3
	3	-	-	E94X C03	553451	E94X D03	553515	3
	4	-	-	E94X C04	553452	E94X D04	553516	3
	6	E94X B06	553389	E94X C06	553453	E94X D06	553517	3
	10	E94X B10	553391	E94X C10	553455	E94X D10	553519	3
	13	E94X B13	553392	E94X C13	553456	E94X D13	553520	3
	16	E94X B16	553393	E94X C16	553457	E94X D16	553521	3
	20	E94X B20	553394	E94X C20	553458	E94X D20	553522	3
	25	E94X B25	553395	E94X C25	553459	E94X D25	553523	3
	32	E94X B32	553396	E94X C32	553460	E94X D32	553524	3
	40	E94X B40	553397	E94X C40	553461	E94X D40	553525	3
	50	E94X B50	553398	E94X C50	553462	E94X D50	553526	3
	63	E94X B63	553399	E94X C63	553463	E94X D63	553527	3

(1) 1P, 240V:
 0.5 ≤ In ≤ 4A Icu = 100kA
 4A < In ≤ 25A Icu = 25kA
 25A < In ≤ 40A Icu = 20kA
 40A < In ≤ 63A Icu = 15kA



Miniature circuit breakers for universal current

Series E90S UC

EN/IEC 60898-2 6000 T15
DIN VDE 0641

EN/IEC 60947-2 10kA

Applications



Standards/Marking

EN/IEC 60898-2
DIN VDE 0641



Add-on devices

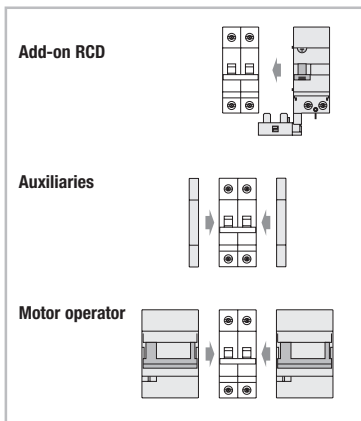

- Add-on RCD ● pg B.15
- Auxiliary contacts ● pg A.24
- Shunt trip ● pg A.24
- Undervoltage release ● pg A.24
- Motor operator ● pg A.24

- Accessories ● pg A.25
- Busbars ● chapter C
- Dimensions ● pg A.7

Performance

Thermal setting (In)	(A)	0.5-63
Rated voltage AC (Un)	(V)	230/400
		250/500/880 ⁽¹⁾ ≡
Minimum operating voltage UB min	(V)	12
		12 ≡
Tripping characteristics		B-C
Mechanical/electrical endurance		20000/10000
Tropicalisation acc.to IEC 60068-2		95%RH at 55°C
Terminal capacity flexible/rigid cable	(mm ²)	25-35
Poles ⁽¹⁾		1, 2, 4
Weight	(g/pole)	125
Thermal operating limit		(1.13 - 1.45) x In
Magnetic operating		B: (3 - 5) x In
		C: (5 - 10) x In

Short-circuit capacity

AC/DC acc. to IEC 60898-2⁽²⁾



Poles	V	Icn=Ics (kA) ⁽³⁾
1	125 DC	10
	220 DC	6
	230/400 AC	6
2	250 DC	10
	440 DC	6
	400 AC	6
4	880 DC	6

AC/DC acc. to IEC 60947-2

Poles	V	Icu (kA)
1	125 DC	20 ⁽⁴⁾
	220 DC	10 ⁽⁴⁾
2	440 DC	10 ⁽⁴⁾
	230 AC	6 ⁽⁵⁾
1	440 AC	6 ⁽⁵⁾

- (1) For 4P execution open circuit voltage $U_{co} = 1000V \equiv$
- (2) After a switching of the net with more than 6kA in AC, is use in DC impossible
- (3) Polarity labeling to be respected due to the permanent magnet in the MCB
- (4) T = 4ms
- (5) 4.5kA for 50A & 63A

Series E90S UC - 10kA - AC/DC MCBs

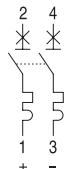
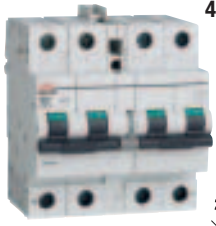
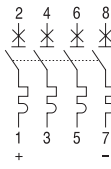
Pole width	Rated current [A]	B		C		Pack.
		Cat. No.	Ref. No.	Cat. No.	Ref. No.	
1P 1 mod.  	0.5	-	-	E91S UC C0.5	553304	12
	1	-	-	E91S UC C01	553305	12
	2	-	-	E91S UC C02	553306	12
	3	-	-	E91S UC C03	553307	12
	4	-	-	E91S UC C04	553308	12
	6	E91S UC B06	553271	E91S UC C06	553309	12
	8	E91S UC B08	553272	E91S UC C08	553310	12
	10	E91S UC B10	553273	E91S UC C10	553311	12
	13	E91S UC B13	553274	E91S UC C13	553312	12
	16	E91S UC B16	553275	E91S UC C16	553313	12
	20	E91S UC B20	553276	E91S UC C20	553314	12
	25	E91S UC B25	553277	E91S UC C25	553315	12
	32	E91S UC B32	553278	E91S UC C32	553316	12
	40	E91S UC B40	553279	E91S UC C40	553317	12
50	E91S UC B50	553280	E91S UC C50	553318	12	
63	E91S UC B63	553281	E91S UC C63	553319	12	
2P 2 mod.  	0.5	-	-	E92S UC C0.5	553320	6
	1	-	-	E92S UC C01	553321	6
	2	-	-	E92S UC C02	553322	6
	3	-	-	E92S UC C03	553323	6
	4	-	-	E92S UC C04	553324	6
	6	E92S UC B06	553290	E92S UC C06	553325	6
	8	E92S UC B08	553291	E92S UC C08	553326	6
	10	E92S UC B10	553292	E92S UC C10	553327	6
	13	E92S UC B13	553293	E92S UC C13	553328	6
	16	E92S UC B16	553294	E92S UC C16	553329	6
	20	E92S UC B20	553295	E92S UC C20	553330	6
	25	E92S UC B25	553296	E92S UC C25	553331	6
	32	E92S UC B32	553297	E92S UC C32	553332	6
	40	E92S UC B40	553298	E92S UC C40	553333	6
50	E92S UC B50	553299	E92S UC C50	553334	6	
63	E92S UC B63	553300	E92S UC C63	553335	6	
4P 4.5 mod.(1)  	10	E94S UC B10	691213	-	-	3
	16	E94S UC B16	691214	-	-	3
	20	E94S UC B20	691215	-	-	3
	32	E94S UC B32	691600	-	-	3
	40	E94S UC B40	691216	-	-	3
	63	E94S UC B63	691217	-	-	3

(1) Including auxiliary contact CAH (central half module)
 Line to be connected to bottom terminals 1, 7 load to 3, 5.

Example of wiring in a photovoltaic application

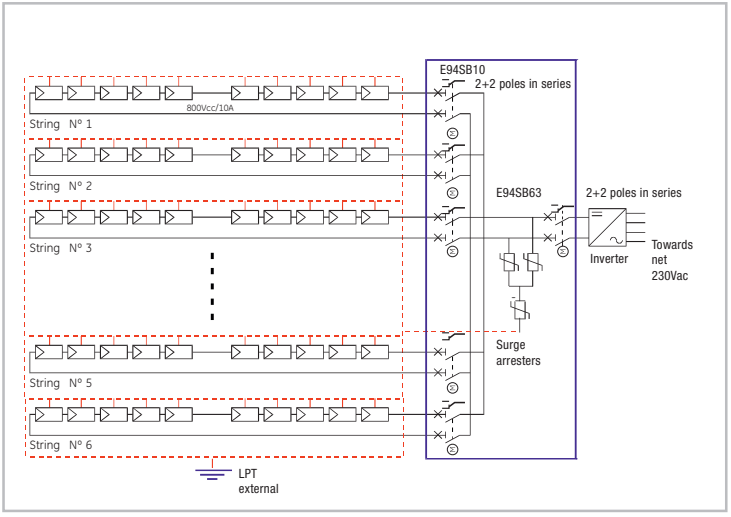
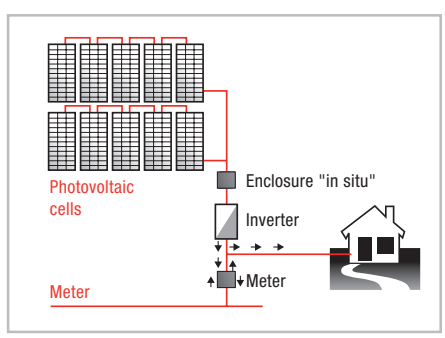

Example of installation in enclosure "in situ"



Miniature circuit breakers

Series E880

EN/IEC 60947-2 6kA

Applications



Standard/Marking

EN/IEC 60947-2

Add-on devices

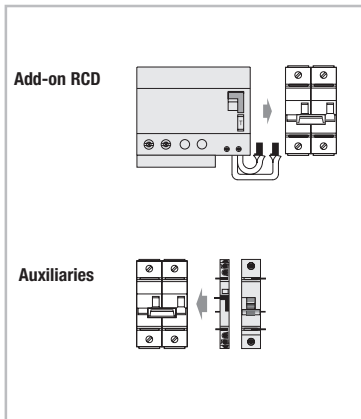

- Add-on RCD ● pg B.15
- Auxiliary contacts ● pg A.24
- Shunt trip ● pg A.24
- Undervoltage release ● pg A.24

Dimensions ● pg A.19

Performance

Thermal setting (In)	(A)	80-100-125
Rated voltage AC (Un)	(V)	240/415
Tripping characteristics		B-C-D
Mechanical/electrical endurance		10000/4000
Operating temperature	(°C)	-25 up to 55
Terminal capacity flexible/rigid cable	(mm ²)	70
Poles		1, 2, 3, 4
Weight	(g/pole)	210
Thermal operating limit		(1.05 - 1.30) x In
Magnetic operating		B: (3 - 5) x In C: (5 - 10) x In D: (10 - 20) x In

Short-circuit capacity

Acc. to EN/IEC 60947-2

Poles	V	Icu (kA)
1	230/400	6
2	230	10
3, 4	230	10
	400	6

Series E880 - 6kA - AC MCBs



1P
1.5 mod.



Pole width	Rated current [A]	B		C		D		Pack.
		Cat. No.	Ref. No.	Cat. No.	Ref. No.	Cat. No.	Ref. No.	
27mm	80	E881 B080	676600	E881 C080	676612	E881 D080	676624	8
	100	E881 B100	676601	E881 C100	676613	E881 D100	676625	1
	125	E881 B125	676602	E881 C125	676614	E881 D125	676626	1



3P
3 mod.

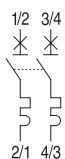

27mm	80	E882 B080	676603	E882 C080	676615	E882 D080	676627	4
	100	E882 B100	676604	E882 C100	676616	E882 D100	676628	1
	125	E882 B125	676605	E882 C125	676617	E882 D125	676629	1



3P
4.5 mod.

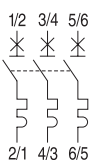

27mm	80	E883 B080	676606	E883 C080	676618	E883 D080	676630	1
	100	E883 B100	676607	E883 C100	676619	E883 D100	676631	1
	125	E883 B125	676608	E883 C125	676620	E883 D125	676632	1

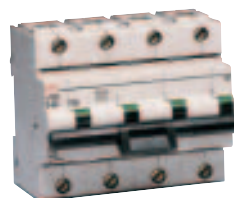

4P
6 mod.

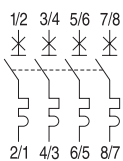

27mm	80	E884 B080	676609	E884 C080	676621	E884 D080	676633	1
	100	E884 B100	676610	E884 C100	676622	E884 D100	676634	1
	125	E884 B125	676611	E884 C125	676623	E884 D125	676635	1

Dimensions - Series E880, E880S

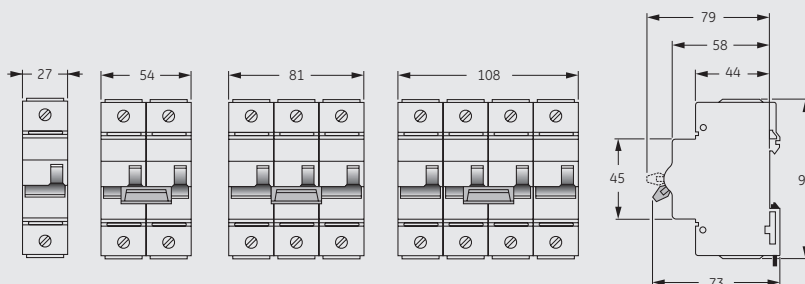



Miniature circuit breakers

Series E880S

EN/IEC 60947-2 10kA

Applications



Standard/Marking

EN/IEC 60947-2

Add-on devices

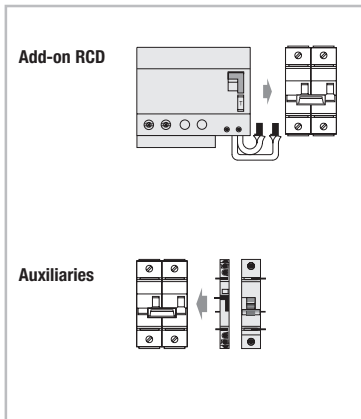

- Add-on RCD ● pg B.15
- Auxiliary contacts ● pg A.24
- Shunt trip ● pg A.24
- Undervoltage release ● pg A.24

Dimensions ● pg A.19

Performance

Thermal setting (I_n)	(A)	80-100-125
Rated voltage AC (U_n)	(V)	240/415
Tripping characteristics		B-C-D
Mechanical/electrical endurance		10000/4000
Operating temperature	(°C)	-25 up to 55
Terminal capacity flexible/rigid cable	(mm ²)	70
Poles		1, 2, 3, 4
Weight	(g/pole)	210
Thermal operating limit		(1.05 - 1.30) x I _n
Magnetic operating		B: (3 - 5) x I _n C: (5 - 10) x I _n D: (10 - 20) x I _n

Short-circuit capacity

Acc. to EN/IEC 60947-2 (B-C)

Poles	V	I _{cu} (kA) ⁽¹⁾
1	230	10 ⁽²⁾
2	230	15 ⁽³⁾
3, 4	230	15 ⁽³⁾
	400	10 ⁽²⁾

(1) Only for B and C

(2) 7.5kA for D

(3) 10kA for D

Series E880S - 10kA - AC MCBs



1P
1.5 mod.



Pole width	Rated current [A]	B		C		D ⁽¹⁾		Pack.
		Cat. No.	Ref. No.	Cat. No.	Ref. No.	Cat. No.	Ref. No.	
27mm	80	E881S B080	676636	E881S C080	676648	E881S D080	676660	
	100	E881S B100	676637	E881S C100	676649	E881S D100	676661	
	125	E881S B125	676638	E881S C125	676650	E881S D125	676662	



2P
3 mod.



27mm	80	E882S B080	676639	E882S C080	676651	E882S D080	676663	
	100	E882S B100	676640	E882S C100	676652	E882S D100	676664	
	125	E882S B125	676641	E882S C125	676653	E882S D125	676665	



3P
4.5 mod.

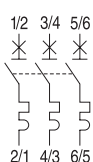

27mm	80	E883S B080	676642	E883S C080	676654	E883S D080	676666	
	100	E883S B100	676643	E883S C100	676655	E883S D100	676667	
	125	E883S B125	676644	E883S C125	676656	E883S D125	676668	

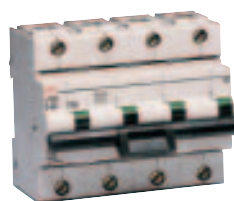

4P
6 mod.

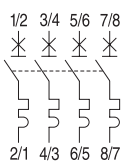

27mm	80	E884S B080	676645	E884S C080	676657	E884S D080	676669	
	100	E884S B100	676646	E884S C100	676658	E884S D100	676670	
	125	E884S B125	676647	E884S C125	676659	E884S D125	676671	

(1) Rated breaking capacity see footnotes (2) and (3) on page A.20



Miniature circuit breakers

Series S90

EN 60898-1 25000

EN 60947-2 **25kA**

Applications



Marking

CE

Performance

Thermal setting (In)	(A)	10-100
Rated voltage AC (Un)	(V)	230/400
Minimum operating voltage AC $U_{B\ min}$	(V)	207
Tripping characteristics		E, F, C
Selectivity class		3
Electrical endurance		4000
Tropicalisation acc.to IEC 60068-2		95%RH at 55°C
Terminal capacity	(mm ²)	2.5-50 (1.5-35)
Poles		1, 1+N, 3, 3+N, 3x1
Weight	(g/pole)	350
Thermal operating limit		Cs: (1.13 - 1.45) x In E: (1.05 - 1.2) x In F: (1.05 - 1.3) x In
Magnetic operating		Cs: (6.5 - 10) x In E: (5 - 6.5) x In F: (6.5 - 10) x In

Short-circuit capacity

AC/DC acc. to EN/IEC 60898-1

Poles	V	Icn (kA)
1, 3, 3+N	230/400	25

- Accessories ● pg A.25
- Busbars ● chapter C
- Dimensions ● pg A.23

Series S90 - 25kA - AC MCBs



**1P+N
3 mod.**

Pole width	Rated current [A]	C ⁽¹⁾		E		F ⁽¹⁾		Pack.
		Cat. No.	Ref. No.	Cat. No.	Ref. No.	Cat. No.	Ref. No.	
27mm	20	S91+N CS020	672540	-	-	-	-	2
	25	S91+N CS025	672541	-	-	-	-	2
	32	S91+N CS032	672542	-	-	-	-	2
	35	S91+N CS035	672543	-	-	-	-	2
	40	S91+N CS040	672544	-	-	-	-	2
	50	S91+N CS050	672545	-	-	-	-	2
	63	S91+N CS063	672546	-	-	-	-	2
	80	S91+N CS080	672547	-	-	-	-	2
	100	S91+N CS100	672548	-	-	-	-	2

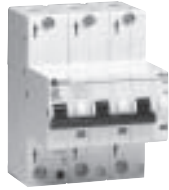

**3P
4.5 mod.**

27mm	20	S93 CS020	672549	-	-	-	-	1
	25	S93 CS025	672550	-	-	-	-	1
	32	S93 CS032	672551	-	-	-	-	1
	35	S93 CS035	672552	-	-	-	-	1
	40	S93 CS040	672553	-	-	-	-	1
	50	S93 CS050	672554	-	-	-	-	1
	63	S93 CS063	672555	-	-	-	-	1
	80	S93 CS080	672556	-	-	-	-	1
	100	S93 CS100	672557	-	-	-	-	1

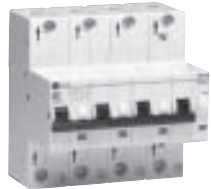

**3P+N
6 mod.**

27mm	20	S93+N CS020	672558	-	-	-	-	1
	25	S93+N CS025	672559	-	-	-	-	1
	32	S93+N CS032	672560	-	-	-	-	1
	35	S93+N CS035	672561	-	-	-	-	1
	40	S93+N CS040	672562	-	-	-	-	1
	50	S93+N CS050	672563	-	-	-	-	1
	63	S93+N CS063	672564	-	-	-	-	1
	80	S93+N CS080	672565	-	-	-	-	1
	100	S93+N CS100	672566	-	-	-	-	1



**1P
1.5 mod.**

27mm	10	-	-	S91 E010	672500	S91 F010	672520	3
	16	-	-	S91 E016	672501	S91 F016	672521	3
	20	S91 CS020	672482	S91 E020	672502	S91 F020	672522	3
	25	S91 CS025	672483	S91 E025	672503	S91 F025	672523	3
	32	S91 CS032	672484	S91 E032	672504	S91 F032	672524	3
	35	S91 CS035	672485	S91 E035	672505	S91 F035	672525	3
	40	S91 CS040	672486	S91 E040	672506	S91 F040	672526	3
	50	S91 CS050	672487	S91 E050	672507	S91 F050	672527	3
	63	S91 CS063	672488	S91 E063	672508	S91 F063	672528	3
	80	S91 CS080	672489	S91 E080	672509	S91 F080	672529	3
	100	S91 CS100	672490	S91 E100	672510	S91 F100	672530	3



**3 x 1P
6 mod.**







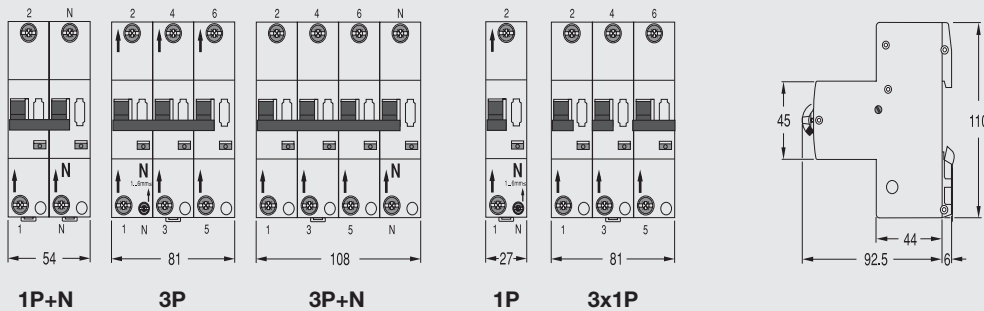

27mm	20	S91.3 CS020	672491	S91.3 E020	672511	S91.3 F020	672531	1
	25	S91.3 CS025	672492	S91.3 E025	672512	S91.3 F025	672532	1
	32	S91.3 CS032	672493	S91.3 E032	672513	S91.3 F032	672533	1
	35	S91.3 CS035	672494	S91.3 E035	672514	S91.3 F035	672534	1
	40	S91.3 CS040	672495	S91.3 E040	672515	S91.3 F040	672535	1
	50	S91.3 CS050	672496	S91.3 E050	672516	S91.3 F050	672536	1
	63	S91.3 CS063	672497	S91.3 E063	672517	S91.3 F063	672537	1
	80	S91.3 CS080	672498	S91.3 E080	672518	S91.3 F080	672538	1
	100	S91.3 CS100	672499	S91.3 E100	672519	S91.3 F100	672539	1

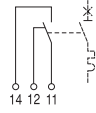
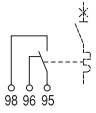
(1) Curves C and F under consult

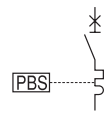
Dimensions - Series S90

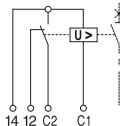

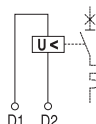
Add-on devices

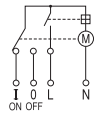
		Description	Width (mm)	Cat. No.	Ref. No.	Pack.	
 <p>Auxiliary contact block 1/2 mod.</p> 	<p>To be coupled to Series E90, E90P EFI, EHFI, D/HD90 1CO</p>		9	H	676034	10	
		<p>To be coupled to Series E880 1CO</p>	9	H	671597	10	
	 <p>Tripping-signal or auxiliary contact block 1/2 mod.</p>	<p>To be coupled to Series E880 1CO</p>	9	S/H	671599	10	
		 <p>Tripping-signal switch with reset button 1/2 mod.</p>	<p>To be coupled to Series E90, E90P 1CO 2CO</p>	9 9	S/H SRH/HH	676035 567819	10 10
	<p>To be coupled to Series E880 1CO</p>		9	SR	671602	10	
	 <p>Miniature circuit breakers interlock 1/2 mod.</p> 	Panelboard switch		9	NLVS	676038	10
 <p>Remote release 1 mod.</p> 		<p>To be coupled to Series E90, EC90, EC91, E90P EFI, EHFI, D/HD90 AC 24 - 60V, DC 24 - 48V AC 110 - 415V, DC 110 - 125V</p>	18 18	NF4 NF5	567820 567821	10 10	
	<p>To be coupled to Series E880 AC 24 - 60V, DC 24 - 48V AC 110 - 415V, DC 110 - 125V</p>	18 18		546532 546533	10 1		
	 <p>Undervoltage trip 1 mod.</p> 	<p>To be coupled to Series E90, EC90, EC91, E90P EFI, EHFI, D/HD90 can be subsequently fitted to both sides of miniature circuit breakers</p>	18 18 18 18		NUVR 230 NUVR 12 NUVR 24 NUVR 48	676039 676040 676041 676042	1 1 1 1
		<p>AC 230V</p>					
<p>AC/DC 12V</p>							
<p>AC/DC 24V</p>							
 <p>Remote drive 3 mod.</p> 	<p>To be coupled to Series E90, EC90, EC91, E90P EFI, EHFI, D/HD90</p>		54	NFA	676043	1	

Accessories



For Series E90

Padlocking bracket for E90 + S90

Cat. No.

KS

Ref. No.

624929

Pack.

2



Sealing plate for 4 poles

EPP

669486

10

For Series S90

Disconnect inhibitor for series S90, 3-pole
to lock the mcb from disconnecting

AST

555681

10



Busbar adapter for S90
1-pole (up to 63A)

SAV 91

546292

10

Technical data of MCBs

Series			E90N	E90E	E90	
Standards			EN/IEC 60898-1	EN/IEC 60898-1	EN/IEC 60898-1	
Tripping characteristics			B, C	B, C	B, C, D, K	
Nominal current	A		2-40	2-40	B 6-63, C/D/K 0.5-63	
Calibration temperature	°C		30	30	30	
Number of poles			1/2/3/4	1/2/3/4	1/2/3/4, 1+N, 3+N	
Neutral pole protected			-	-	yes	
Nominal voltage Un	AC	1P	V	240/415	240/415	240/415
		1P+N	V	-	240	240
		2P	V	415	415	415
	DC	3P/3P+N/4P	V	415	415	415
		1P ⁽¹⁾	VDC	-	-	48
		2P (in series) ⁽¹⁾	VDC	-	-	110
Frequency			Hz	50/60	50/60	50/60
			Hz	-	-	DC: magn.trip +40%
			Hz	400: magn.trip +50%	400: magn.trip +50%	400: magn.trip +50%
Maximum service voltage U _{bmax} between two wires	V		250/440	250/440	250/440; 53/120 ==	
Minimum service voltage U _{bmin}	V		12	12	12; 12 ==	
Selectivity class (IEC 60898-1)			3	3	3	
Isolator application IEC 60947-2			yes	yes	yes	
Rated insulation voltage	Pollution degree 2		V	500	500	500
	Pollution degree 3		V	440	440	440
Impulse withstand test voltage			kV	6	6	6
Insulation resistance	MΩ		10.000	10.000	10.000	
Dielectric rigidity	kV		2.5	2.5	2.5	
Vibrations resistance in x, y, z direction (IEC 77/16.3)			3g	3g	3g	
Endurance	electrical at U _n , I _n		# op.	10.000	10.000	10.000
	mechanical		# op.	20.000	20.000	20.000
Utilisation category (IEC 60947-2)			A	A	A	
Mounting position (for all devices): any except upside down			any	any	any	
Incoming top or bottom			yes	yes	yes	
Protection degree (outside / inside enclosure with door)			IP20/IP40	IP20/IP40	IP20/IP40	
Self-extinguish degree (according to UL94)			V2	V2	V2	
Tropicalisation (according to EN/IEC 60068-2 / DIN 40046)	°C/RH		+55/95%	+55/95%	+55/95%	
Operating temperature	°C		-25/+55	-25/+55	-25/+55	
Storage temperature	°C		-55/+55	-55/+55	-55/+55	
Terminal capacity	Rigid cable min/max (top)		mm ²	1/35	1/35	1/35
	Flexible cable min*/max (top)		mm ²	0.75/25	0.75/25	0.75/35
	Rigid cable min/max (bottom)		mm ²	1/35	1/35	1/35
	Flexible cable min*/max (bottom)		mm ²	0.75/25	0.75/25	0.75/35
	(*Flexible cable 0.75/1/1.5 mm ² with cable lug)					
	Torque		Nm	4.5	4.5	4.5
Add-on devices (side add-on)	Auxiliary contacts			yes	yes	yes
	Remote release NF			yes	yes	yes
	Undervoltage trip NUVR			yes	yes	yes
	Remote drive NFA			yes	yes	yes
	Panel board switch NLVS			yes	yes	yes
Busbar systems	Pin (top/bottom)		yes/yes	yes/yes	yes	
	Fork (top/bottom)		-/yes	-/yes	-/yes	
Accessories				yes	yes	
Width per mod.	(mm)		18	18	18	
Weight per mod.	(gr)		120	120	125	
Package	# mod.		12	12	12	
Approvals			VDE	VDE	VDE	
CE-marking			yes	yes	yes	
Page			A.6	A.8	A.10	

(1) Preferred values of rated control supply voltage (IEC 60947-2): 24V, 48V, 110V, 125V, 220V, 250V

E90S	E90X	E90S UC	E880/E880-S	S90
EN/IEC 60898-1	EN/IEC 60947-2	(2)	EN/IEC 60947-2	EN/IEC 60898-1, E DIN VDE 0645
B, C, D	3-5In/5-10In/10-20In	B, C	3-5In/5-10In/10-20In	F, Cs, E
B 6-63, C/D 0.5-63	B 6-63, C/D 0.5-63	B 6-63, C 0.5-63	80 upto 125	F, E 10/100 and Cs 20/100
30	50	30	40	E 20°C, F and Cs 30°C
1/2/3/4, 1+N, 3+N	1/2/3/4	1/2	1/2/3/4	1, 3x1, 1+N, 3, 3+N
yes	-	-	-	no
240/415	240/415	240/415	240/415	230
240	-	-	-	230
415	415	415	415	-
415	415	-	415	400
48	48	220	48	-
110	110	440	110	-
50/60	50/60	50/60 and DC	50/60	50/60
DC: magn.trip +40%	DC: magn.trip +40%	DC: magn.trip +40%	DC: magn.trip +40%	-
400: magn.trip +50%	400: magn.trip +50%	400: magn.trip +50%	400: magn.trip +50%	-
250/440; 53/120 ==	250/440; 53/120 ==	250/440; 250/440 ==	250/440; 53/120 ==	250/440 ~
12; 12 ==	12; 12 ==	12; 12 ==	12; 12 ==	207 ~
3	3	3	-	-
yes	yes	yes	yes	-
500	500	500	500	-
440	440	440	440	-
6	6	6	6	6
10.000	10.000	10.000	10.000	10.000
2.5	2.5	2.5	2.5	-
3g	3g	5g	3g	3g
10.000	10.000	1000	4000	4.000
20.000	20.000	20.000	10.000	4.000
A	A	A	A	B
any	any	any	any	any
yes	yes	follow polarity	yes	bottom only
IP20/IP40	IP20/IP40	IP20/IP40	IP20/IP40	IP20/IP40
V2	V2	V2	V2	V0
+55/95%	+55/95%	+55/95%	+55/95%	-
-25/+55	-25/+55	-25/+55	-25/+55	-25/+55
-55/+55	-55/+55	-55/+55	-55/+55	-55/+55
1/35	1/35	1/35	70	1.5/35
0.75/35	0.75/35	0.75/25	-	-
1/35	1/35	1/35	70	2.5/50
0.75/35	0.75/35	0.75/25	-	-
4.5	4.5	4.5	5	4
yes	yes	yes	yes	yes
yes	yes	yes	-	-
yes	yes	yes	yes	-
yes	yes	yes	-	-
yes	yes	yes	-	-
yes/yes	yes/yes	yes/yes	-	-
-/yes	-/yes	-/yes	-	-
yes	yes	yes	yes	-
18	18	18	27	27
120	120	125	210	350
12	12	12	8	8
VDE	-	-	-	VDE for E-char.
yes	yes	yes	yes	yes
A.12	A.14	A.16	A.18/A.20	A.22

(2) EN/IEC 60898-2 and VDE0641-2/3

Short-circuit capacity of MCBs				E90N	E90E	E90	
Series							
Short-circuit capacity AC (kA)							
IEC 60898-1	Icn	1P	230/400V	3	4.5	6	
		1P+N	230V	3	4.5	6	
		2P	230/400V	3	4.5	6	
		3P/3P+N/4P	230/400V	3	4.5	6	
	Ics (service)			100% Icn	100% Icn	100% Icn	
IEC 60947-2	Icu (ultimate) 1P	127V		-	-	20	
		240V		5	6	10	
		415V		3	3	3	
	1P+N/2P	127V		-	15	30	
		240V		10	10	20	
	2P	415V		5	6	10	
		240V		10	10	20	
	3P, 4P	415V		5	6	10	
		440V		-	-	6	
	Ics (service)			75% Icu	75% Icu	75% Icu	
NEMA AB1 (120/240V)				10	14	20	
Short-circuit capacity DC (kA)							
IEC 60947-2	Icu (ultimate) 1P	≤ 60V ==		-	-	20	
		≤ 220V ==		-	-	-	
		2P	≤ 125V ==		-	-	25
			≤ 440V ==		-	-	-
	Ics (service)			-	-	100% Icu	
Page				A.6	A.8	A.10	

	E90S	E90X	E90SUC	E880	E880S	S90
	10	-	6 (220VDC) ⁽²⁾	-	-	25
	10	-	-	-	-	25
	10	-	6 (440VDC) ⁽³⁾	-	-	25
	10	-	-	-	-	25
	75% Icn	-	100% Icn	-	-	-
	30	50	-	-	-	-
	15	50/25/20/15 ⁽¹⁾	6 ⁽⁵⁾	6	10; D7.5	-
	4	-	-	6	4.5	-
	40	-	-	10	-	-
	30	50/50/40/30 ⁽¹⁾	-	10	B/C 15	-
	15	50/25/20/15 ⁽¹⁾	6 ⁽⁵⁾	6	B/C 10; D7.5	-
	30	50/50/40/30 ⁽¹⁾	-	10	B/C 15	-
	15	50/25/20/15 ⁽¹⁾	-	6	B/C 10; D7.5	-
	10	50/20/15/10 ⁽¹⁾	-	-	-	-
	50% Icu	50% Icu	-	100% Icu	100% Icu	-
	30	-	-	-	-	-
	25	25	-	-	-	-
	-	-	-	-	-	-
	30	30	10 ⁽⁴⁾	-	-	-
	-	-	-	-	-	-
	100% Icu	100% Icu	10 ⁽⁴⁾	100% Icu	100% Icu	-
	A.10	A.12	A.16	A.18	A.20	A.22

(1) 0.5-4A/6-25A/32-40A/50-63A

(2) 10 (125VDC)

(3) 10 (250VDC)

(4) T=4ms

(5) 4.5kA for 50A & 63A

EN/IEC 60898-1 standard

Circuit breakers are intended for the protection against overcurrents of wiring installations in buildings and similar applications:

They are designed for use by un instructed people and for not being maintained.

Tripping characteristic curves

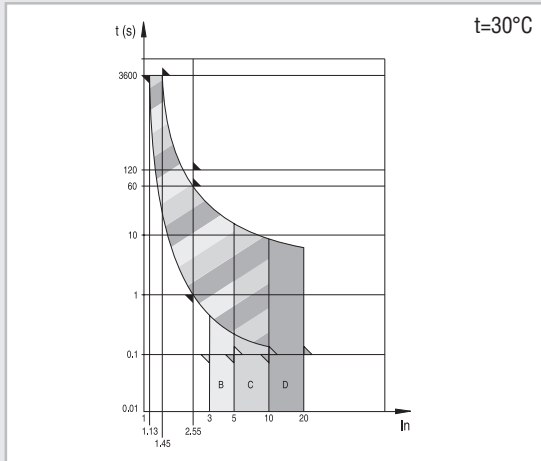

Magnetic release

An electromagnet with plunger ensures instantaneous tripping in case of short circuit. The IEC 60898-1 distinguishes three different types, following the current for instantaneous release: type B, C, D.

Test current	Tripping time	Applications
B 3 In 5 In	0.1 < t < 45s (In ≤ 32A) 0.1 < t < 90s (In ≤ 32A) t < 0.1s	Only for resistive loads such as: - electrical heating - water heater - stoves
C 5 In 10 In	0.1 < t < 15s (In ≤ 32A) 0.1 < t < 30s (In ≤ 32A) t < 0.1s	Usual loads such as: - lighting - socket outlets - small motors
D 10 In 20 In	0.1 < t < 4s ⁽¹⁾ (In ≤ 32A) 0.1 < t < 8s (In ≤ 32A) t < 0.1s	Control and protection of circuits having important transient inrush currents (large motors)

⁽¹⁾if In ≤ 10A, t < 8s

Thermal release

The release is initiated by a bimetal strip in case of overload.

The standard defines the range of release for specific overload values.

Reference ambient temperature is 30°C

Test current	Tripping time
1.13 In	t ≥ 1h (In ≤ 63A) t ≥ 2h (In > 63A)
1.45 In	t < 1h (In ≤ 63A) t < 2h (In > 63A)
2.55 In	1s < t < 60s (In ≤ 32A) 1s < t < 120s (In > 32A)

EN/IEC 60947-2 standard

Low voltage switchgear and controlgear Part 2: circuit breakers

This standard applies to circuit breakers, the main contacts of which are intended to be connected to circuits, the rated voltage of which does not exceed 1000V ac or 1500V dc.

Circuit breakers for use in industrial environments (for use by instructed people).

Tripping characteristic curves

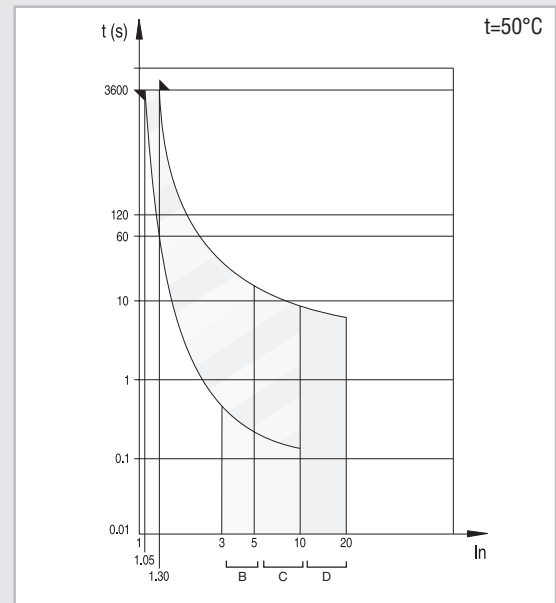

Curve K (EN/IEC 60947-2) versus B,C,D (EN/IEC 60898-1)

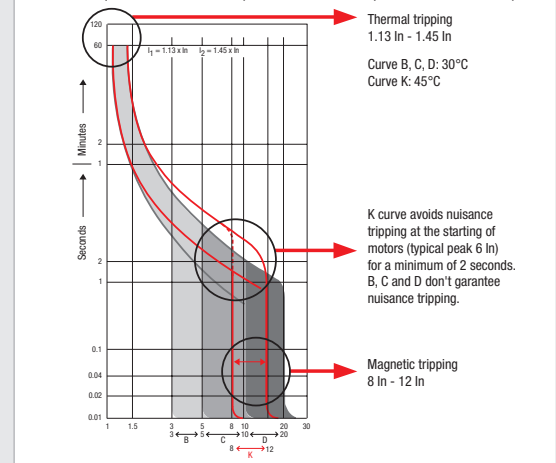

Magnetic release

An electromagnet with plunger ensures instantaneous tripping in case of short circuit.

The standard leaves the calibration of magnetic release to manufacturers decision.

AEG Low Voltage offers instantaneous tripping ranges

- release B: 4 In
- release C: 8.5 In (7.5 In for 63A)
- release D: 14 In
- release K: 10 In (6 In > 2 s)

Thermal release

The release is initiated by a bimetal strip in case of overload.

The standard defines the range of release for two special overload values. Reference ambient temperature is 50°C, except K: 45°C

Test current	Tripping time
1.05 In	t ≥ 1h (In ≤ 63A) t ≥ 2h (In > 63A)
1.30 In	t < 1h (In ≤ 63A) t < 2h (In > 63A)

Influence of ambient temperature (according EN/IEC 60898-1)

The thermal calibration of the MCBs was carried out at an ambient temperature of 30°C. Ambient temperatures different from 30°C influence the bimetal and this results in earlier or later thermal tripping (see curve).

Voltage drop and energy loss

0.5 - 6A

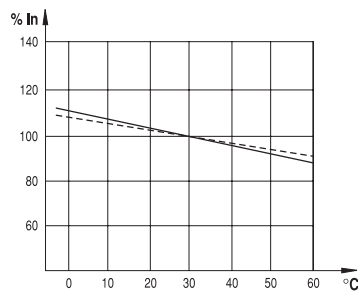

50 - 63A

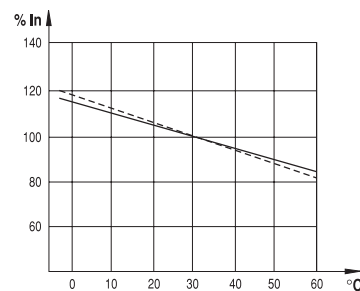

16 - 40A

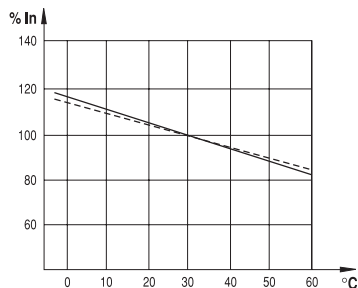

10A

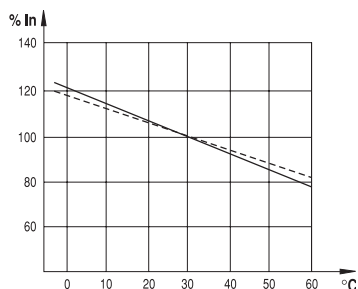

— : 1P (single pole)
- - : mP (multipole)

In (A)	Voltage drop (V)	Energy loss (W)	Inner resistant (mΩ)
0.5	2.230	1.115	4458.0
1	1.270	1.272	1272.0
2	0.620	1.240	310.0
3	0.520	1.557	173.0
4	0.370	1.488	93.0
6	0.260	1.570	43.6
8	0.160	1.242	19.4
10	0.160	1.560	15.6
13	0.155	2.011	11.9
16	0.162	2.586	10.1
20	0.138	2.760	6.9
25	0.128	3.188	5.1
32	0.096	3.072	3.0
40	0.100	4.000	2.5
50	0.090	4.500	1.8
63	0.082	5.160	1.3
80	0.075	6.000	0.9
100	0.075	7.500	0.75
125	0.076	9.500	0.6

Notes

A large rectangular area filled with a fine grid of small squares, intended for taking notes. The grid is composed of approximately 25 columns and 40 rows of squares.

Unibis™ - Compact miniature circuit breakers

- A.34 Benefits
- A.36 **Series EC 91E NR** - Miniature circuit breakers 1P+N - 4.5 kA
- A.37 **Series EC 91 NR** - Miniature circuit breakers 6 kA
- A.38 **Series EC 911** - Miniature circuit breakers 1P+1P - 6 kA
- A.40 **Series EC 91E** - Miniature circuit breakers 4.5 kA
- A.42 **Series EC 90** - Miniature circuit breakers 6 kA
- A.44 **Series DA 41N** - Miniature circuit breakers 1P+N - 4.5 kA
- A.45 **Series CA UN** - Unibis™ Interface auxiliary
- A.46 Technical data
- A.39 Dimensions

Quick overview

Page no.	Series	Applications	Poles	Add-on devices	Tripping curve	Rating current (A)	Short-circuit capacity (kA)	
A.36	EC 91E NR		1+N (1 mod.)	yes	B-C	2 - 40	4.5	6
A.37	EC 91 NR		1+N (1 mod.)	yes	B-C	2 - 40	6	10 ⁽¹⁾
A.38	EC 911		1P+1P (1 mod.)	yes	B-C	2+2 - 20+20	6	6
A.40	EC 90E		2, 3, 4	yes	B-C	6 - 32	4.5	6
A.42	EC 90		2	yes	B-C	2 - 40	6	10 ⁽²⁾
			3, 4	yes	B-C	2 - 32	6	6
A.44	DA 41N		1+N (1 mod.)	yes	C	6 - 40	4.5	

domestic
 commercial

B: 3-5 In
 C: 5-10 In

EN/IEC 60898-1
 EN/IEC 60947-2

(1) 8000 for 32 and 40A
 (2) At Un = 240Vac

A

B

C

D

E

F

G

H

I

J

K

L

M

X

Benefits of the compact Unibis™ MCBs

- 2 circuits in 1 module
- Unibis™: the solution for space problems

Unibis™ MCBs are one of the latest introductions in the AEG MCBs range and are developed to reduce the size of the distribution board to the minimum. The performances are upgraded to 10kA.

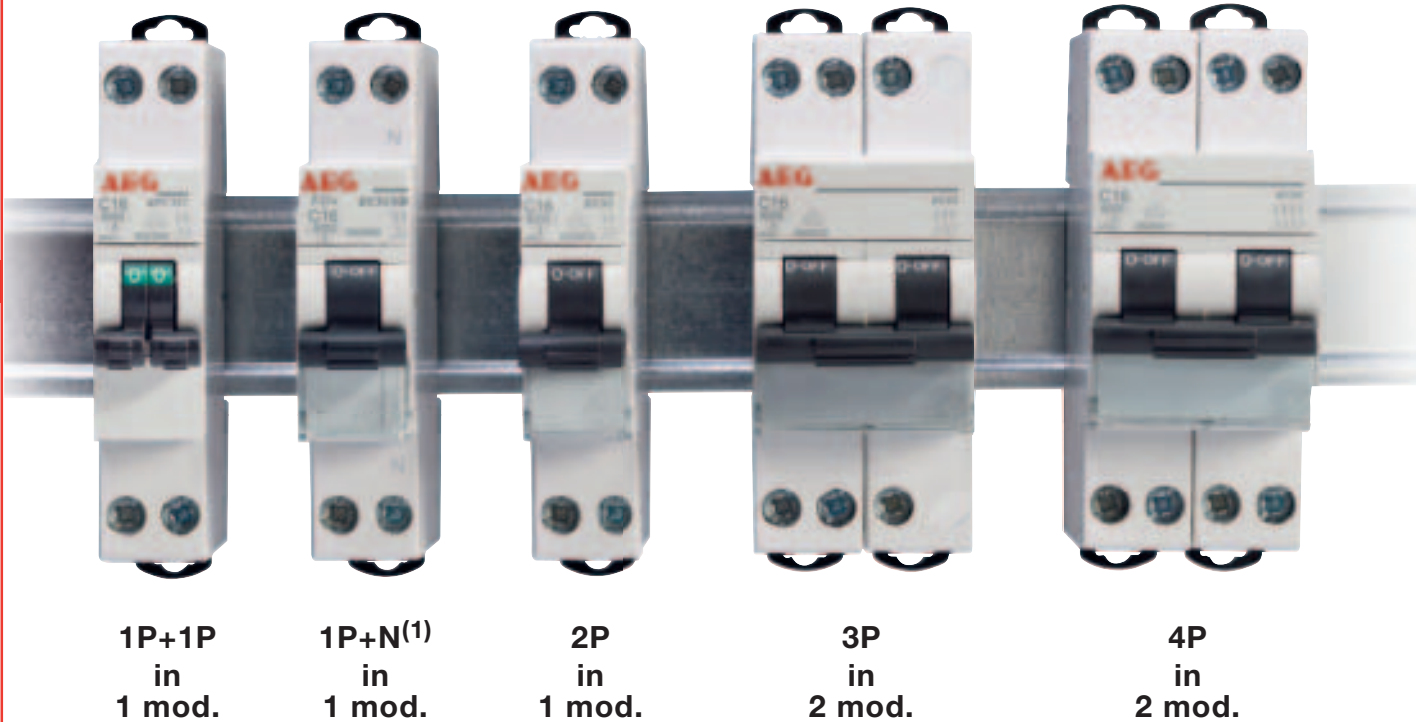

**1P+1P
in
1 mod.**

**1P+N⁽¹⁾
in
1 mod.**

**2P
in
1 mod.**

**3P
in
2 mod.**

**4P
in
2 mod.**

- ✓ Brandnew design:
2P in 1 module,
3P and 4P in 2 modules
- ✓ Complete range: from 4.5–6–10kA⁽²⁾,
2–40 Amps, B and C curves
- ✓ 100% compatible with all AEG
MCBs auxiliaries and accessories
- ✓ 100% Series E90 quality and reliability
- ✓ VDE certified

3 performances
up to 10kA

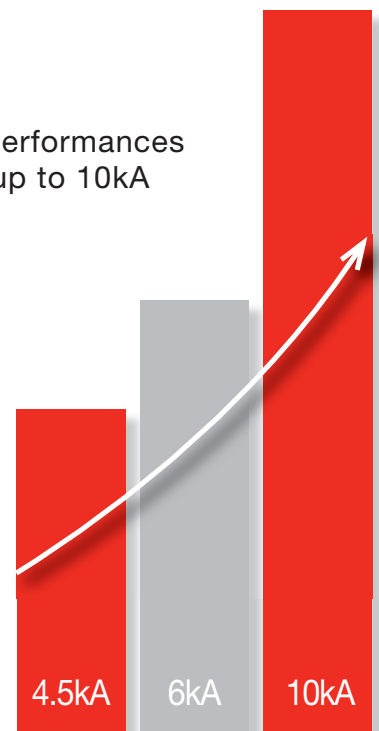

(1) Neutral left or right available

(2) 1P+N and 2P according IEC 60749-2

Saving up to 50% space in distribution boards!

**Replacing standard
MCBs by compact
Unibis™ MCBs**

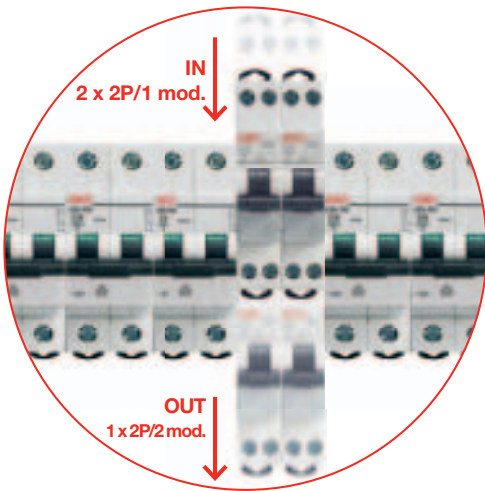

Quality and reliability guaranteed

Unibis™

A

	<p>High performance clips To fix the MCB to the DIN-rail.</p>		<p>High performance torque Up to 3Nm.</p>
<p>Easy to replace Double clips make it easy to replace the MCBs, especially when a busbar is installed.</p>		<p>Userfriendly All screws are on the same level to work fast and easy.</p>	
	<p>Green or red flag on toggle with isolation applications Correct information about the real position. Minimum 5mm distance between open contacts is ensured.</p>		<p>Part of the family Unibis™ MCBs fit perfectly in the AEG MCBs range.</p>
<p>Safety terminals IP20 The capacity of Unibis™ terminals has been doubled. Connection possibilities: (2 x 4mm²) or (1 x 4mm²) + (1 x 6mm²).</p>		<p>Full functionality A small auxiliary contact is the interface to the complete functionality of the AEG MCBs auxiliaries and accessories.</p>	



Compact MCBs Unibis™

Series EC 91E NR

EN/IEC 60898-1	4500
	3
EN/IEC 60947-2	6kA

Applications



Approvals / Marking



Add-on devices

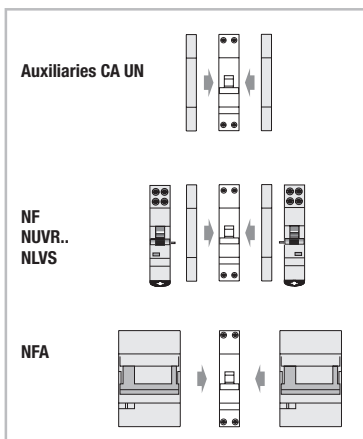

When coupling an add-on device (remote release NF, undervoltage trip NUVR.., panel-board switch NLVS) to the MCB, a CA UN auxiliary has to be coupled first as interface. Not needed with remote drive NFA.

Auxiliary contacts CA ● pg. A.45
 Auxiliary contacts ● pg. A.24
 Other auxiliaries ● pg. A.24

Busbars ● pg. C.10
 Dimensions ● pg. A.39

Performance

Thermal setting (In)	(A) 2-40
Rated voltage AC (Un)	(V) 230
Minimum operating voltage UBmin	(V) 12
Tripping characteristics	B-C
Selectivity class	3
Mechanical/electrical endurance	20000/10000 ⁽¹⁾
Tropicalisation acc. to EN/IEC 60068-2	55°C at 95% RH
Terminal capacity flexible/rigid cable	(mm ²) 10-16 ⁽²⁾
Poles	1P+N (1 mod)
Weight	(g) 125

Short-circuit capacity

Acc. to EN/IEC 60898-1

Poles	V	Icn/Ics (kA)
1P+N	230	4.5

Acc. to EN/IEC 60947-2

Poles	V	Icu (kA)
1P+N	230	6

Attention: do not use on IT net configuration

Series EC 91E NR - 4.5kA - characteristics B-C

In (A)	B		C		Pack.
	Cat. No.	Ref. No.	Cat. No.	Ref. No.	
6	EC91E B06NR	692876	EC91E C06NR	692858	12
10	EC91E B10NR	692877	EC91E C10NR	692859	12
16	EC91E B16NR	692878	EC91E C16NR	692860	12
20	EC91E B20NR	692879	EC91E C20NR	692861	12
25	EC91E B25NR	692880	EC91E C25NR	692862	12
32	EC91E B32NR	692881	EC91E C32NR	692863	12



⁽¹⁾ 8000 for 32 and 40A

⁽²⁾ Also accepting (2x4mm²) or (1x4mm²)+(1x6mm²)

Compact MCBs Unibis™

Series EC 91 NR



EN/IEC 60898-1

6000

3

EN/IEC 60947-2

10kA

Series EC 91 NR

A

Applications



Approvals / Marking



Add-on devices

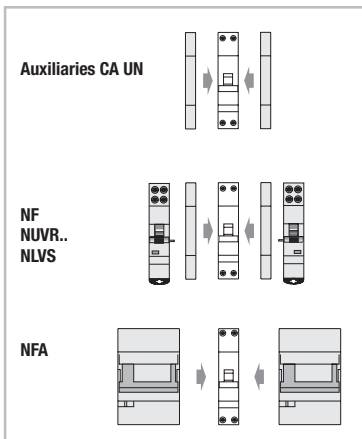

When coupling an add-on device (remote release NF, undervoltage trip NUVR.., panel-board switch NLVS) to the MCB, a CA UN auxiliary has to be coupled first as interface. Not needed with remote drive NFA.

- Auxiliary contacts CA ● pg. A.45
- Auxiliary contacts ● pg. A.24
- Other auxiliaries ● pg. A.24

- Busbars ● pg. C.10
- Dimensions ● pg. A.39

Performance

Thermal setting (In)	(A) 2-40
Rated voltage AC (Un)	(V) 230
Minimum operating voltage U_{Bmin}	(V) 12
Tripping characteristics	B-C
Selectivity class	3
Mechanical/electrical endurance	20000/10000 ⁽¹⁾
Tropicalisation acc. to EN/IEC 60068-2	55°C at 95% RH
Terminal capacity flexible/rigid cable	(mm ²) 10-16 ⁽²⁾
Poles	1P+N (1 mod)
Weight	(g) 125

Short-circuit capacity

Acc. to EN/IEC 60898-1

Poles	V	Icn/Ics (kA)
1P+N	230	6

Acc. to EN/IEC 60947-2

Poles	V	Icu (kA)
1P+N	230	10

Attention: do not use on IT net configuration

Series EC 91 NR - 6kA - characteristics B-C

In (A)	B		C		Pack.
	Cat. No.	Ref. No.	Cat. No.	Ref. No.	
2	EC91 B02NR	692883	EC91 C02NR	692865	12
4	EC91 B04NR	692884	EC91 C04NR	692866	12
6	EC91 B06NR	692885	EC91 C06NR	692867	12
10	EC91 B10NR	692886	EC91 C10NR	692868	12
13	EC91 B13NR	692602	EC91 C13NR	692601	12
16	EC91 B16NR	692887	EC91 C16NR	692869	12
20	EC91 B20NR	692888	EC91 C20NR	692870	12
25	EC91 B25NR	692889	EC91 C25NR	692871	12
32	EC91 B32NR	692890	EC91 C32NR	692872	12
40	EC91 B40NR	692891	EC91 C40NR	692873	12

(1) 8000 for 32 and 40A

(2) Also accepting (2x4mm²) or (1x4mm²)+(1x6mm²)



Compact MCBs Unibis™

Two independent circuits in one module!

Series EC 911

EN/IEC 60898-1

6000
3

Applications



Approval / Marking



Add-on devices

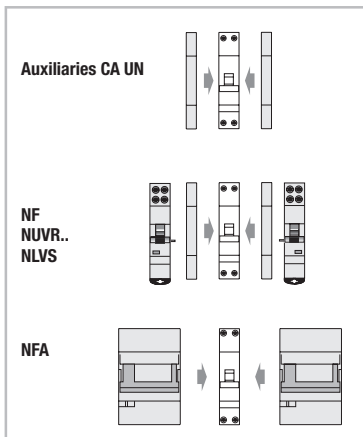

When coupling an add-on device (remote release NF, undervoltage trip NUVR.., panel-board switch NLVS) to the MCB, a CA UN auxiliary has to be coupled first as interface. Not needed with remote drive NFA.

- Auxiliary contacts CA ● pg. A.45
- Auxiliary contacts ● pg. A.24
- Other auxiliaries ● pg. A.24

- Busbars ● pg. C.10
- Dimensions ● pg. A.39

Performance

Thermal setting (In)	(A)	2-40
Rated voltage AC (Un)	(V)	240 ⁽¹⁾
Minimum operating voltage U _{Bmin}	(V)	12
Tripping characteristics		B-C
Selectivity class		3
Mechanical/electrical endurance		20000/10000 ⁽²⁾
Tropicalisation acc. to EN/IEC 60068-2		55°C at 95% RH
Terminal capacity flexible/rigid cable	(mm ²)	10-16 ⁽³⁾
Poles		1P+1P (1 mod)
Weight	(g)	125

Short-circuit capacity

Acc. to EN/IEC 60898-1

Poles	V	I _{cn} /I _{cs} (kA)
1+1	240	6

Series EC 911- 6kA - characteristics B-C

In (A)	B		C		Pack.	
	Cat. No.	Ref. No.	Cat. No.	Ref. No.		
1P+1P 1 mod. 	2	EC 911 B02B02	692581	EC 911 C02C02	692591	12
	4	EC 911 B04B04	692582	EC 911 C04C04	692592	12
	6	EC 911 B06B06	692583	EC 911 C06C06	692593	12
	10	EC 911 B10B10	692584	EC 911 C10C10	692594	12
	13	EC 911 B13B13	692585	EC 911 C13C13	692595	12
	16	EC 911 B16B16	692586	EC 911 C16C16	692596	12
	20	EC 911 B20B20	692587	EC 911 C20C20	692597	12

- (1) Single phase supply or same phase in 3Ph supply
- (2) 8000 for 32 and 40A
- (3) Also accepting (2x4mm²) or (1x4mm²)+(1x6mm²)

Dimensional drawings

Miniature Circuit Breakers - Series EC 91E NR, EC 91 NR, EC 911 + EC 90

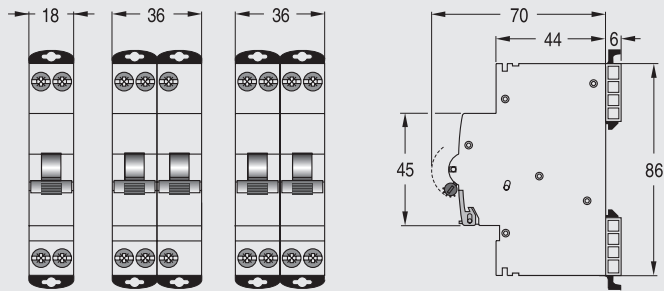

Auxiliary interface - Series CA UN

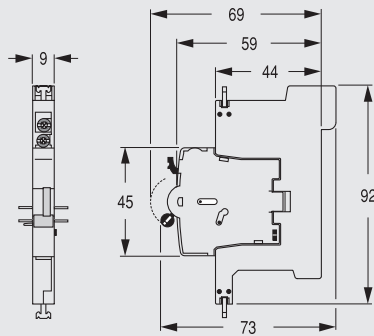



Compact MCBs Unibis™

Series EC 90E

EN/IEC 60898-1	4500
	3
EN/IEC 60947-2	6kA

Applications



Approvals / Marking



Add-on devices

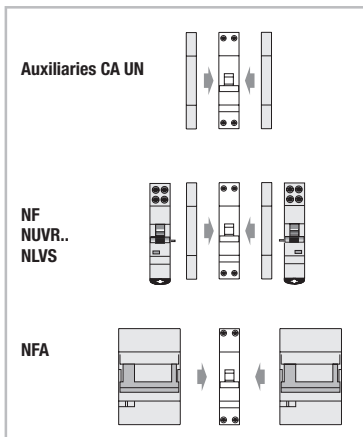

When coupling an add-on device (remote release NF, undervoltage trip NUVR., panel-board switch NLVS) to the MCB, a CA UN auxiliary has to be coupled first as interface. Not needed with remote drive NFA.

- Auxiliary contacts CA ● pg. A.45
- Auxiliary contacts ● pg. A.24
- Other auxiliaries ● pg. A.24

- Busbars ● pg. C.10
- Dimensions ● pg. A.39

Performance

Thermal setting (In)	(A) 2-40 ⁽¹⁾
Rated voltage AC (Un)	(V) 240/415
Minimum operating voltage UBmin	(V) 12
Tripping characteristics	B-C
Selectivity class	3
Mechanical/electrical endurance	20000/10000 ⁽²⁾
Tropicalisation acc. to EN/IEC 60068-2	55°C at 95% RH
Terminal capacity flexible/rigid cable	(mm ²) 10-16 ⁽³⁾
Poles	2, 3, 4
Weight	(g) 160

(1) 8000 for 32 and 40A

Short-circuit capacity

Acc. to EN/IEC 60898-1

Poles	V	Icn/Ics (kA)
2P	415	4.5
3P	415	4.5
4P	415	4.5

Acc. to EN/IEC 60947-2

Poles	V	Icu (kA)
2P	240	6
3P	415	6
4P	415	6

(1) 32A, 3P & 4P in progress

(2) 8000 for 32 and 40A

(3) Also accepting (2x4mm²) or (1x4mm²)+(1x6mm²)

EC 90E- 4.5kA - characteristics B-C



2P
1 mod.



In (A)	B		C		Pack.
	Cat. No.	Ref. No.	Cat. No.	Ref. No.	
6	EC 92 E B06	692975	EC 92 E C06	692894	12
10	EC 92 E B10	692976	EC 92 E C10	692895	12
16	EC 92 E B16	692977	EC 92 E C16	692896	12
20	EC 92 E B20	692978	EC 92 E C20	692897	12
25	EC 92 E B25	692979	EC 92 E C25	692898	12
32	EC 92 E B32	692980	EC 92 E C32	692899	12



3p(1)
1 mod.

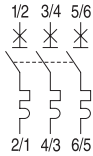

6	EC 93 E B06	692984 ⁽¹⁾	EC 93 E C06	692903 ⁽¹⁾	6
10	EC 93 E B10	692985 ⁽¹⁾	EC 93 E C10	692904 ⁽¹⁾	6
16	EC 93 E B16	692986 ⁽¹⁾	EC 93 E C16	692905 ⁽¹⁾	6
20	EC 93 E B20	692987 ⁽¹⁾	EC 93 E C20	692906 ⁽¹⁾	6
25	EC 93 E B25	692988 ⁽¹⁾	EC 93 E C25	692907 ⁽¹⁾	6
32	EC 93 E B32	692989 ⁽¹⁾	EC 93 E C32	692908 ⁽¹⁾	6



4P
2 mod.

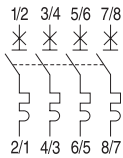

6	EC 94 E B06	692993	EC 94 E C06	692912	6
10	EC 94 E B10	692994	EC 94 E C10	692913	6
16	EC 94 E B16	692995	EC 94 E C16	692914	6
20	EC 94 E B20	692996	EC 94 E C20	692915	6
25	EC 94 E B25	692997	EC 94 E C25	692916	6
32 ⁽²⁾	EC 94 E B32	692998	EC 94 E C32	692917	6

(1) The auxiliary contact CA UN must be placed only on the **left side** of the 3P MCBs



Compact MCBs Unibis™

Series EC 90

EN/IEC 60898-1

6000

3

EN/IEC 60947-2

10kA⁽¹⁾

Applications



Approvals / Marking



Add-on devices

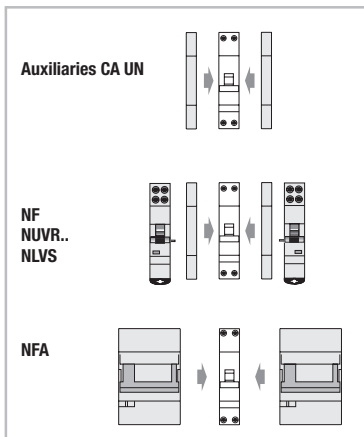

When coupling an add-on device (remote release NF, undervoltage trip NUVR., panel-board switch NLVS) to the MCB, a CA UN auxiliary has to be coupled first as interface. Not needed with remote drive NFA.

- Auxiliary contacts CA ● pg. A.45
- Auxiliary contacts ● pg. A.24
- Other auxiliaries ● pg. A.24

- Busbars ● pg. C.10
- Dimensions ● pg. A.39

Performance

Thermal setting (In)	(A) 2-40 ⁽²⁾
Rated voltage AC (Un)	(V) 240/415
Minimum operating voltage UBmin	(V) 12
Tripping characteristics	B-C
Selectivity class	3
Mechanical/electrical endurance	20000/10000 ⁽³⁾
Tropicalisation acc. to EN/IEC 60068-2	55°C at 95% RH
Terminal capacity flexible/rigid cable	(mm ²) 10-16 ⁽⁴⁾
Poles	2, 3, 4
Weight	(g) 160

(1) 8000 for 32 and 40A

Short-circuit capacity

Acc. to EN/IEC 60898-1

Poles	V	Icn/Ics (kA)
2P	415	6
3P	415	6
4P	415	6

Acc. to EN/IEC 60947-2

Poles	V	Icu (kA)
2P	240	10
2P	415	6
3P	415	6
4P	415	6

(1) 6kA at 415V

(2) 32A, 3P & 4P

(3) 8000 for 32 and 40A

(4) Also accepting (2x4mm²) or (1x4mm²)+(1x6mm²)

EC 90- 6kA - characteristics B-C



**2P
1 mod.**

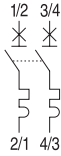

In (A)	B		C		Pack.
	Cat. No.	Ref. No.	Cat. No.	Ref. No.	
2	EC 92 B02	693000	EC 92 C02	692919	12
4	EC 92 B04	693001	EC 92 C04	692920	12
6	EC 92 B06	693002	EC 92 C06	692921	12
10	EC 92 B10	693003	EC 92 C10	692922	12
16	EC 92 B16	693004	EC 92 C16	692923	12
20	EC 92 B20	693005	EC 92 C20	692924	12
25	EC 92 B25	693006	EC 92 C25	692925	12
32	EC 92 B32	693007	EC 92 C32	692926	12
40	EC 92 B40	693008	EC 92 C40	692927	12



**3P(1)
1 mod.**

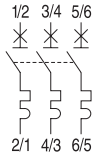

2	EC 93 B02	693009 ⁽¹⁾	EC 93 C02	692928 ⁽¹⁾	6
4	EC 93 B04	693010 ⁽¹⁾	EC 93 C04	692929 ⁽¹⁾	6
6	EC 93 B06	693011 ⁽¹⁾	EC 93 C06	692930 ⁽¹⁾	6
10	EC 93 B10	693012 ⁽¹⁾	EC 93 C10	692931 ⁽¹⁾	6
16	EC 93 B16	693013 ⁽¹⁾	EC 93 C16	692932 ⁽¹⁾	6
20	EC 93 B20	693014 ⁽¹⁾	EC 93 C20	692933 ⁽¹⁾	6
25	EC 93 B25	693015 ⁽¹⁾	EC 93 C25	692934 ⁽¹⁾	6
32 ⁽²⁾	EC 93 B32	693016 ⁽¹⁾	EC 93 C32	692935 ⁽¹⁾	6



**4P
2 mod.**

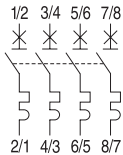

2	EC 94 B02	693018	EC 94 C02	692937	6
4	EC 94 B04	693019	EC 94 C04	692938	6
6	EC 94 B06	693020	EC 94 C06	692939	6
10	EC 94 B10	693021	EC 94 C10	692940	6
16	EC 94 B16	693022	EC 94 C16	692941	6
20	EC 94 B20	693023	EC 94 C20	692942	6
25	EC 94 B25	693024	EC 94 C25	692943	6
32	EC 94 B32	693025	EC 94 C32	692944	6

(1) The auxiliary contact CA UN must be placed only on the **left side** of the 3P MCBs



Compact MCBs Unibis™

Series DA 41 N

EN/IEC 60898-1

4500
3

Applications



Approval / Marking



Dimensional drawings

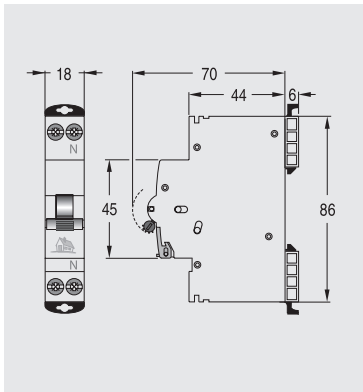

Performance

Thermal setting (In)	(A) 2-40
Rated voltage AC (Un)	(V) 230
Minimum operating voltage UBmin	(V) 12
Tripping characteristics	C
Selectivity class	3
Mechanical/electrical endurance	20000/10000 ⁽¹⁾
Tropicalisation acc. to EN/IEC 60068-2	55°C at 95% RH
Terminal capacity flexible/rigid cable	(mm ²) 10-16 ⁽²⁾
Poles	1P+N (1 mod)
Weight	(g) 125

Short-circuit capacity

Acc. to EN/IEC 60898-1

Poles	V	Icn/Ics (kA)
1P+N	230	4.5

Series DA 41 N- 4.5kA - characteristics B-C

	In (A)	C		Pack.
		Cat. No.	Ref. No.	
1P + N 1 mod.	6	DA 41 N C06	693079	12
	10	DA 41 N C10	693080	12
	16	DA 41 N C16	693081	12
1/2 N	20	DA 41 N C20	693082	12
	25	DA 41 N C25	693083	12
	32	DA 41 N C32	693084	12
2/1 N				

Busbars ● pg. C.10

(1) 8000 for 32 and 40A

(2) Also accepting (2x4mm²) or (1x4mm²)+(1x6mm²)



Applications



Approvals / Marking



Add-on devices

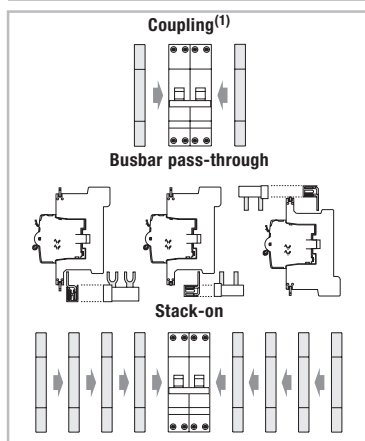

(1) 3P Series EC MCBs accept CA UN only on the left side

Auxiliary

Series CA UN - Series EC Interface EN/IEC 62019

- Especially designed for MCBs Series EC, however also valid for all modular protection devices: MCBs and RCBOs up to 63 A, RCCBs up to 100A and mains disconnect switches type ASTER (ASTM).
- Can be coupled on both sides of MCBs⁽¹⁾ and modular switches type ASTM.
- Version with golden contacts, available for low current as well as low voltage applications.
- Stack-on left or right up to 4 CA UN units.
- Permits the pass-through of busbars, pin & fork, top and bottom, just changing the position of the base of the auxiliaries.

Performance

Change-over contacts	1
Rated current (In)	(A) 5
Rated voltage AC (Un)	(V) 240
Electrical endurance	10000
Terminal capacity flexible/rigid cable	(mm ²) 2.5
Weight	(g) 70
Torque	(Nm) 0.8

Application

The auxiliary contact CA UN has a double function:

1. The standard function as auxiliary monitoring contact for which it has been developed.
2. The interface function, which allows the use of all auxiliaries in combination with the Series EC MCB range.

Example: to couple the undervoltage release NUVR to a Series EC MCB, the CA UN H 672977 has to be added in between the MCB and the NUVR as interface.

The auxiliary contacts are units to be added on to protection devices. They allow information to be monitored from a distance about the protection devices.

Auxiliary contact CA UN H (function H)

Provides the status of the protection device, OPEN/CLOSED.

Signal or auxiliary contact CA UN S/H (function S/H)

This auxiliary can act as an auxiliary contact (function H) or as a signal contact (function S).

The user can change the function at the moment of installation.

Used as signal contact (function S) it provides the information about the automatic tripping of the protection devices: overload or short-circuit for MCBs, earth leakage tripping for RCDs.

- The device has a test button on the front to simulate the function (acting as a function H or S)
- Reset button for the contacts (function S)
- Tripping signal on the front (function S)

Series CA UN - interface auxiliary contact

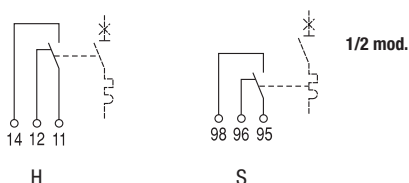

Function	Cat. No.	Ref. No.	Pack.
H	CA UN H	672977	1/40
S/H	CA UN S/H	672978	1/40

Dimensions ● pg. A.39

Technical data of compact MCBs - Unibis™

Series			EC 91E NR	EC 91 NR
Standards			EN/IEC 60898-1	EN/IEC 60898-1
Tripping characteristics			B,C	B,C
Nominal current (In)			2-40	2-40
Calibration temperature (°C)			30	30
Number of poles (# mod)			1+N (1 mod)	1+N (1 mod)
Neutral pole protected			-	-
Nominal voltage Un AC			230	230
1P+N (V)			-	-
1P+1P (V)			-	-
2P (V)			-	-
3P (V)			-	-
4P (V)			-	-
Nominal voltage Un DC (V=)			-	-
Frequency (Hz)			50/60	50/60
			Thresh. magn. + 40%	Thresh. magn. + 40%
			Thresh. magn. + 50%	Thresh. magn. + 50%
Maximum service voltage Ub max (V)			250	250
Minimum service voltage Ub min (V)			12	12
Selectivity class (EN 60898-1)			3	3
Rated insulation voltage			500	500
Pollution degree 2 (V)			400	400
Pollution degree 3 (V)			6	6
Impulse withstand test voltage (kV)			1000	1000
Insulation resistance (MΩ)			2.5	2.5
Dielectric rigidity (kV)			3	3
Vibration resistance in x,y,z direction (IEC 77/16.3) (g)			10000 ⁽²⁾	10000 ⁽²⁾
Endurance			20000	20000
Electrical at Un,In # op.				
Mechanical # op.			A	A
Utilisation category (EN 60947-2)			any	any
Mounting position: vertical/horizontal			yes	yes
Incoming top or bottom			IP20/IP40	IP20/IP40
Protection degree (outside/inside enclosure with door)			V2	V2
Selfextinguish degree (acc. UL 94)			+55°C/95%RH	+55°C/95%RH
Tropicalisation (acc. EN 60068-2/DIN 40046)			-25/+55	-25/+55
Operating temperature (°C)			-55/+55	-55/+55
Storage temperature (°C)			1/16 ⁽³⁾	1/16 ⁽³⁾
Terminal capacity			1/10 ⁽³⁾	1/10 ⁽³⁾
Rigid cable min/max (top) (mm ²)			1/16 ⁽³⁾	1/16 ⁽³⁾
Flexible cable min/max (top) (mm ²)			1/10 ⁽³⁾	1/10 ⁽³⁾
Rigid cable min/max (bottom) (mm ²)			1/16 ⁽³⁾	1/16 ⁽³⁾
Flexible cable min/max (bottom) (mm ²)			3	3
Torque (Nm)			yes	yes
Add-on devices			yes ⁽⁴⁾	yes ⁽⁴⁾
Auxiliary contacts			yes ⁽⁴⁾	yes ⁽⁴⁾
Under voltage trip NUVR			yes ⁽⁴⁾	yes ⁽⁴⁾
Remote release NF			yes ⁽⁴⁾	yes ⁽⁴⁾
Panelboard switch NLVS			yes	yes
Remote drive NFA			yes/yes	yes/yes
Busbar systems			no/no	no/no
Pin (top/bottom)			yes	yes
Fork (top/bottom)			18	18
Accessories			125	125
Width per mod. (mm)			12	12
Weight per mod. (gr)			KEMA, IMQ	VDE, KEMA, IMQ
Package # mod.			yes	yes
Approvals			A.36	A.37
CE-marking				
Page				

Short-circuit capacity of compact MCBs

Series			EC 91E NR	EC 91 NR
Short-circuit capacity AC			(kA)	(kA)
EN/IEC 60898-1 <i>I_{cn}</i>			4.5	6
1P+N 230 V			-	-
1P+1P 230 V			-	-
2P 400 V			-	-
3P 400 V			-	-
4P 400 V			-	-
EN 60947-2 <i>I_{cu}</i>			6	10
1P+N 230 V			-	-
1P+1P 230 V			-	-
2P 230 V			-	-
2P 415 V			-	-
3P 415 V			-	-
4P 415 V			-	-
Short-circuit capacity DC				
EN 60947-2 <i>I_{cu}</i>			-	-
2P 96 V=				

EC 911	EC 90E	EC 90	DA 41N
EN/IEC 60898-1	EN/IEC 60898-1	EN/IEC 60898-1	EN/IEC 60898-1
B,C	B,C	B,C	C
2-20	6-32 ⁽¹⁾	2-40 ⁽¹⁾	2-40
30	30	30	30
1P+1P (1 mod)	2 (1 mod), 3&4 (2 mod)	2 (1 mod), 3&4 (2 mod)	1+N (1 mod)
-	-	-	-
-	-	-	230
230 ⁽⁵⁾	-	-	-
-	400	400	-
-	400	400	-
-	400	400	-
-	96	96	-
50/60	50/60	50/60	50/60
Thresh. magn. + 40%	Thresh. magn. + 40%	Thresh. magn. + 40%	Thresh. magn. + 40%
Thresh. magn. + 50%	Thresh. magn. + 50%	Thresh. magn. + 50%	Thresh. magn. + 50%
250/440	250/440	250/440	250
12	12	12	12
3	3	3	3
500	500	500	500
400	400	400	400
6	6	6	6
1000	10000	10000	1000
2.5	2.5	2.5	2.5
3	3	3	3
10000 ⁽²⁾	10000 ⁽²⁾	10000 ⁽²⁾	10000 ⁽²⁾
20000	20000	20000	20000
A	A	A	A
any	any	any	any
yes	yes	yes	yes
IP20/IP40	IP20/IP40	IP20/IP40	IP20/IP40
V2	V2	V2	V2
+55°C/95%RH	+55°C/95%RH	+55°C/95%RH	+55°C/95%RH
-25/+55	-25/+55	-25/+55	-25/+55
-55/+55	-55/+55	-55/+55	-55/+55
1/16 ⁽³⁾	1/16 ⁽³⁾	1/16 ⁽³⁾	1/16 ⁽³⁾
1/10 ⁽³⁾	1/10 ⁽³⁾	1/10 ⁽³⁾	1/10 ⁽³⁾
1/16 ⁽³⁾	1/16 ⁽³⁾	1/16 ⁽³⁾	1/16 ⁽³⁾
1/10 ⁽³⁾	1/10 ⁽³⁾	1/10 ⁽³⁾	1/10 ⁽³⁾
3	3	3	3
yes	yes	yes	no
yes ⁽⁴⁾	yes ⁽⁴⁾	yes ⁽⁴⁾	no
yes ⁽⁴⁾	yes ⁽⁴⁾	yes ⁽⁴⁾	no
yes ⁽⁴⁾	yes ⁽⁴⁾	yes ⁽⁴⁾	no
yes	yes	yes	no
yes/yes	yes/yes	yes/yes	yes/yes
no/no	no/no	no/no	no/no
yes	yes	yes	yes
18	18/36	18/36	18
160	160/320	160/320	125
12/6	12/6	12/6	12
VDE, IMQ	IMQ, NF	VDE, IMQ, NF, CEBEC	IMQ, KEMA
yes	yes	yes	yes
A.39	A.40	A.42	A.44

EC 911	EC 90E	EC 90	DA 41N
(kA)	(kA)	(kA)	(kA)
-	-	-	4.5
6	-	-	-
-	4.5	6	-
-	4.5	6	-
-	4.5	6	-
-	-	-	-
6	-	-	-
-	-	10	-
-	6	6	-
-	6	6	-
-	6	6	-
-	4.5	6	-

(1) 32A, 3P & 4P
(2) 8000 for 32 and 40 A

(3) Also accepting (2x4mm²) or (1x4mm²)+(1x6mm²)
(4) Requires CA auxiliary contact as interface

(5) Single phase supply or same phase in 3Ph supply

Characteristics according to IEC/EN 60898-1

Miniature Circuit Breakers (MCBs) are intended for the protection of wiring installations against both overloads and short-circuits in domestic or commercial wiring installations where operation is possible by uninstructed people.

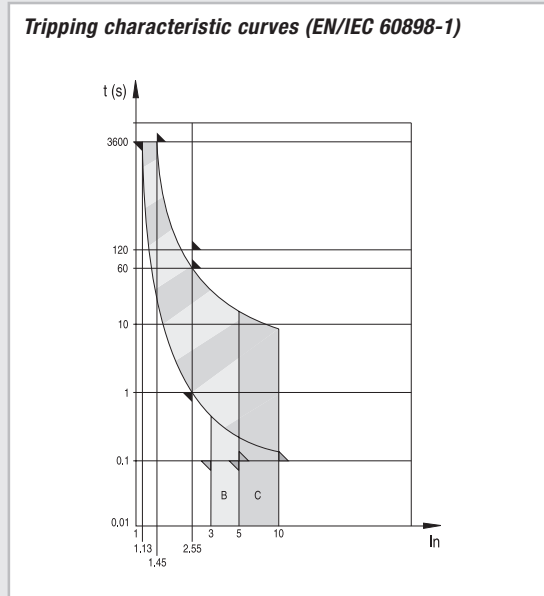

Magnetic release

An electromagnet with plunger ensures instantaneous tripping in the event of short-circuit. The standard distinguishes two different types, following the current for instantaneous release: type B and C.

Icn (A)	Test current	Tripping time	Applications
B	3 x In	0.1 < t < 45s (In ≤ 32A) 0.1 < t < 90s (In > 32A)	Only for resistive loads such as: - electrical heating - water heater - stoves
	5 x In	t < 0.1s	
C	5 x In	0.1 < t < 15s (In ≤ 32A) 0.1 < t < 30s (In > 32A)	Usual loads such as: - lighting - socket-outlets - small motors
	10 x In	t < 0.1s	

Thermal release

The release is initiated by a bimetal strip in case of overload. The standard defines the range of releases for specific overload values.

Reference ambient temperature is 30°C.

Test current	Tripping time
1.13 x In	t ≥ 1h (In ≤ 63A) t ≥ 2h (In > 63A)
1.45 x In	t < 1h (In ≤ 63A) t < 2h (In > 63A)
2.55 x In	1s < t < 60s (In ≤ 32A) 1s < t < 120s (In > 32A)

Influence of ambient air temperature on the rated current

The maximum value of the current which can flow through an MCB depends of the nominal current of the MCB, the conductor cross-section as well as of the ambient air temperature.

The values shown in the diagram below are for devices in free air.

For devices installed with other modular devices in the same switchboard a correction factor (K) shall be applied relative to the mounting situation of the MCB, the ambient temperature and the number of main circuits in the installation (EN 60439-1):

No. of rows in enclosure	K
2 or 3	0.9
4 or 5	0.8
6 to 9	0.7
> 10	0.6

Calculation example

Within a distribution panel consisting of eight rows each 6 of 2 pole C16 with an operating ambient temperature of 45°C, which is the highest temperature at which the MCB can operate without unwanted tripping.

Calculation

The correction factor K=0.7, for use in an eight rows installation: 16A x 0.7= 11.2A

As the MCB is working at 45°C, another factor shall be applied (90% = 0.9):

In at 45°C = In at 30°C x 0.9 = 11.2A x 0.9 = 10.1A

The thermal calibration of the MCBs was carried out at an ambient temperature of 30°C. Ambient temperatures different from 30°C influence the bimetal and this results in earlier or later thermal tripping.

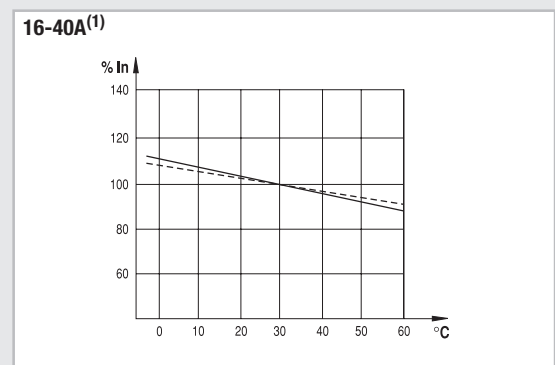

(1) Other ratings see page A.31

Tripping current as a function of the frequency

All MCBs are designed to work at frequencies of 50-60 Hz, therefore to work at different values, consideration must be given to the variation of the tripping characteristics.
The thermal tripping does not change with variation of the frequency but the magnetic tripping values can be up to 50% higher than the ones at 50-60 Hz. For DC current magnetic tripping is 50% higher.

Tripping current variations

60Hz	100Hz	200Hz	300Hz	400Hz
1	1.1	1.2	1.4	1.5

Power losses

The power losses are calculated by measuring the voltage drop between the incoming and the outgoing terminals of the device at rated current.

Power losses per pole

In (A)	Voltage drop (V)	Energy loss Pw (W)	Resistance Z (mOhm)
2	0.55	1.1	275.00
4	0.34	1.35	84.38
6	0.25	1.52	42.22
10	0.16	1.64	16.40
16	0.13	2.1	8.20
20	0.13	2.52	6.30
25	0.12	3.1	4.96
32	0.12	3.8	3.71
40	0.11	4.46	2.79

Toggle⁽¹⁾

The toggle permits to switch the MCB ON or OFF

Printing on the toggle provides information of the real contact position.

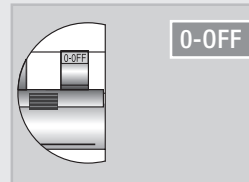

0-OFF

Contacts in open position. Ensures a distance between contacts > 5mm in the Unibus™ range.

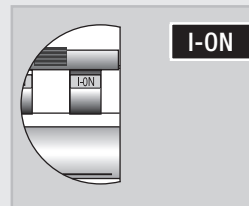

I-ON

Contacts in closed position. Ensures continuity in the main circuit.

(1) Not applicable for Series DA41N

Note: Series DCC has got ON-OFF indication on the shell.

Notes

A large rectangular area filled with a fine grid of small squares, intended for taking handwritten notes. The grid covers most of the page's width and height.